



The Choice for Air and Gas Applications

MR-166S, -185S, -200S, -300 Liquid-Ring Pump

Application

MR is a liquid-ring pump specially designed for pumping liquids containing air or gas. The pump is for use in food, chemical, pharmaceutical and similar industries. The pump is mainly used for CIP-return application.

Standard design

All product wetted parts, i.e. pump casing, casing cover and impeller are made of acid-resistant steel AISI 316L. Seals are made of EPDM rubber. Cap nuts, legs, leg brackets and shroud are made of stainless steel AISI 304. The shroud has noise absorbing lining inside. MR-166S, 185S and 200S: Adaptor is in cast iron which is zinc coated and laquered making it highly corrosion resistant.

Shaft seal

On MR-166S, -185S and 200S, the mechanical single seals have stationary seal rings of acid-resistant steel AISI 329 and rotating seal rings of carbon. The MR-300 has mechanical single seal with stationary seal rings of carbon and rotating seal rings of acid-resistant steel AISI 329.

Technical data

Max. inlet pressure: 400 kPa (4 bar).
 Temperature range: -10°C to +140°C (EPDM).

Motor

Standard foot-flanged motor acc. to IEC metric standard 4 pol = 1500/1800 rpm. at 50/60 Hz.
 IP55 (with drain holes with labyrinth plug), insulation class F.

Voltage and frequency (MR-166S)

3~, 50 Hz, 220-240V Δ/380-420VY
 3~, 60 Hz, 250-280V Δ/440-480VY

Voltage and frequency (MR-185S, -200S and -300)

3~, 50 Hz, 380-420V Δ/660-690VY
 3~, 60 Hz, 440-480V Δ

Motor sizes

50 Hz	60 Hz
2.2 kW (166S)	2.6 kW (166S)
5.5 kW (MR-185S)	6.3 kW (MR-185S)
7.5, 11 kW (MR-200S)	8.6, 12.5 kW (MR-200S)
15, 18.5 kW (MR-300)	17, 21, 25 kW (MR-300)



MR-185S with shroud and legs.

MR-300 with shroud and legs.

Volumetric flow MR-166S, -185S, -200S and -300

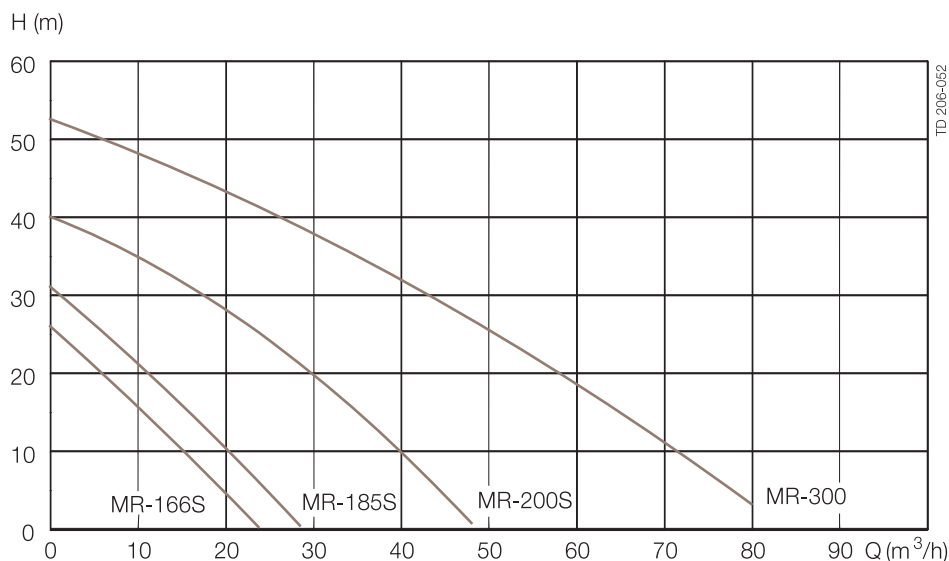

Options

- A. Other voltage and frequency.
- B. Flameproof motors (EEXE and EEXD).
- C. Pump without shroud and legs.
- D. Pump without shroud.
- E. Adaptor in stainless steel AISI 304 (MR-185S and MR-200S only).
- F. Noise reduction valve.
- G. Product wetted seals of Nitrile (NBR) or Fluorinated rubber (FPM).
- H. Stationary seal ring with sealing surface of Silicon Carbide (MR-185S and MR-200S only).
- I. Rotating seal ring of Silicon Carbide (MR-185S and MR-200S only).

Ordering

Please state the following when ordering:

- Pump type.
- Voltage and frequency.
- Connections.
- Flow rate, pressure and temperature.
- Density and viscosity of product.
- Options.

Note!

For further information, see also instruction IM70719 and M70733.

Connections (mm)

MR-166S: Inlet and outlet: 51 mm (2").

Dim.	ISO clamp	ISO male	DIN male	SMS male	BS male
M ⁱ	21	21	22	20	22
M ⁱⁱ	21	21	22	20	22

MR-185S and MR-200S: Inlet and outlet: 76.1 mm (3").

Dim.	ISO clamp	ISO male	DIN male	SMS male	BS male
M ⁱ	21	21	22	24	22
M ⁱⁱ	12	21	32	24	22

MR-300: Inlet and outlet: 76 mm (3").

Dim.	ISO clamp	ISO male	DIN male	SMS male	BS male
M	21	21	30	24	22

Dimensions (mm)

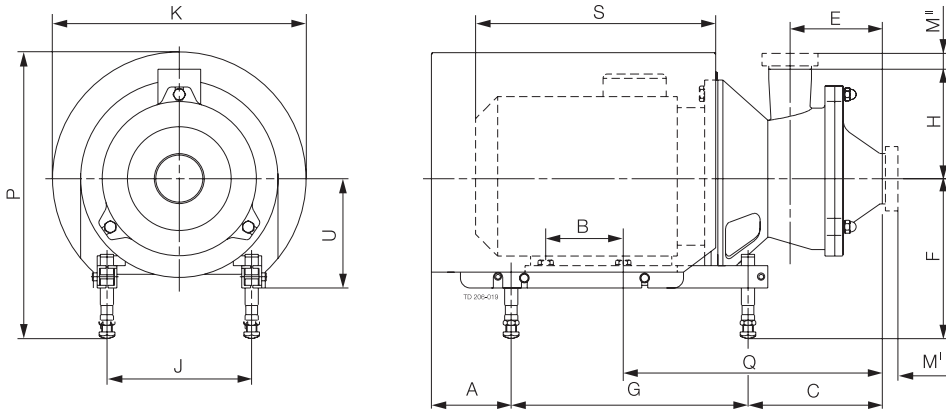

MR-166S/-185S/-200S

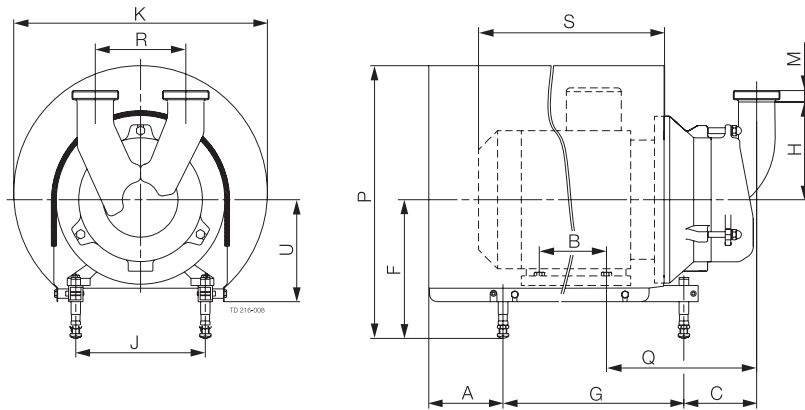

MR-300

Dimensions (mm)

Size	MR-166S	MR-185S/200S	MR-300	
			15 kW	18.5 kW
A	78	81	170	196
B	140	178	210	241
C	185	204	149	162
E	117	140		
F min.	185	184	228	260
F max.	295	317	345	365
G	320	400	483	508
H	129	154	205	205
J	160	216	254	279
K	323	383	485	533
P min.	357	380	486	537
P max.	469	513	603	646
Q	280	339	302	315
R			190	190
*S	299	402	571	616
U	145	167	195	215
Weight (kg)	55	77/85	150	195

Note! *S for pumps with ABB motor

900141/1