



For Your Utility Heating and Cooling

M-Series Plate Heat Exchangers

Applications

For your utility heating and cooling duties the industrial plate heat exchangers of Alfa Laval can be used. These are detailed in the following product sheets.

Standard design

The plate heat exchanger consists of a pack of corrugated metal plates with portholes for the passage of the two fluids between which heat transfer will take place.

The plate pack is assembled between a fix frame plate and a movable pressure plate and compressed by tightening bolts. The plates are fitted with a gasket which seals the interplate channel and directs the fluids into alternate channels. The number of plates is determined by the flow rate, physical properties of the fluids, pressure drop and temperature program. The plate corrugations promote fluid turbulence and support the plates against differential pressure.

The plate and the pressure plate are fixed between upper bar and lower bar, both of which are fixed to a support column.

Connections are located in the frame plate or, if either or both fluids make more than a single pass within the unit, in the frame and pressure plates.

Working principle

Channels are formed between the plates and the corner ports are arranged so that the two media flow through alternate channels. The heat is transferred through the plate between the channels, and complete counter-current flow is created for highest possible efficiency. The corrugation of the plates provides the passage between the plates, supports each plate against the adjacent one and enhances the turbulence, resulting in efficient heat transfer.

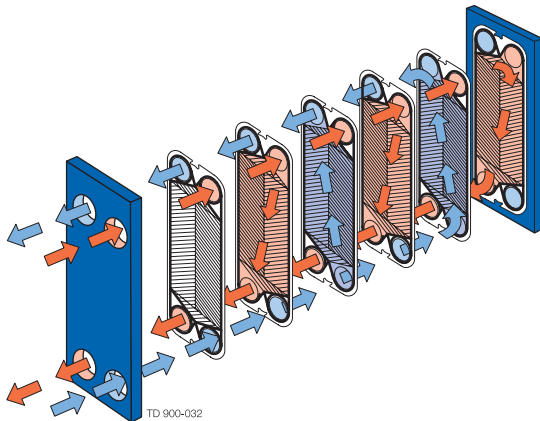

Flow principle of an M3,M6, M10 and M15 plate heat exchanger

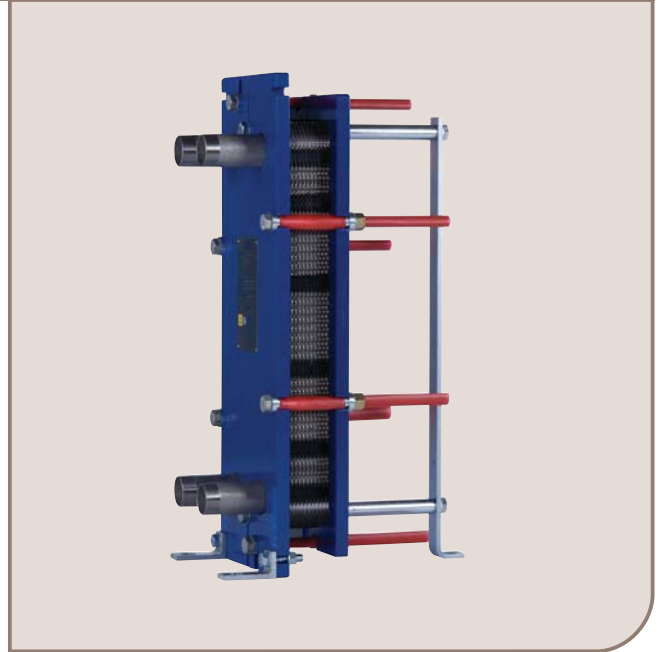

M6-FG

M3

Typical capacities

Liquid flow rate

Up to 4 kg/s (60 gpm), depending on media, permitted pressure drop and temperature program.

Water heating by steam

50 to 250 kW

Plate types

M3 and M3-X, where M3 provides parallel and M3D and M3G, double wall plates.

Frame types

FG

Standard Materials

Frame plate

Mild steel, Epoxy painted

Nozzles

Carbon steel Pipe: Alloy 316, Titanium

Plates

Stainless steel: AISI 316 or Titanium

Gaskets

M3

Nitrile, EPDM, HeatSealF™

M3D

Nitrile, EPDM

Technical Data

Pressure vessel codes, PED, ASME, pvcALS™ Mechanical design pressure (g) / temperature

FG	PED, pvcALS™	1.6 MPa / 180°C
FG	ASME	150 psig / 350°F

Maximum heat transfer surface

3.9 m² (40 sq. ft)

Connections

FG	PED	Size 1¼"	Pipe, thread ISO-R 1¼"
FG	pvcALS™	Size 1¼"	Pipe, thread ISO-G 1¼" or thread ISO-R1¼"
FG	pvcALS™	Size 1¼"	Internal thread ISO-G 1¼", carbon steel
FG	ASME	Size 1¼"	Pipe, thread NPT 1¼"

Dimensions

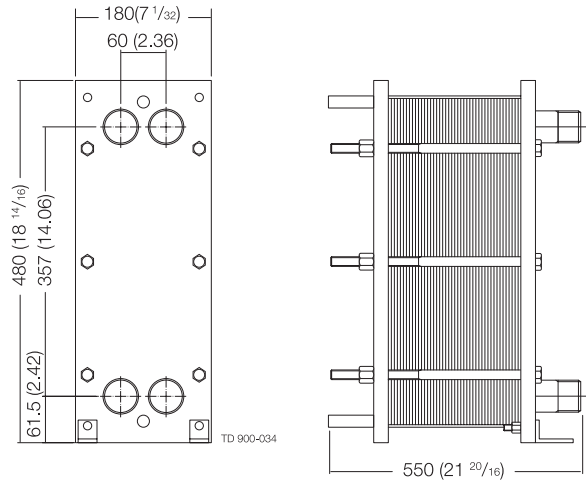

Measurements (mm)

The number of bolts may vary depending on pressure rating.

Particulars required for quotation

- Flow rates or heat load
- Temperature program
- Physical properties of liquids in question (if not water)
- Desired working pressure
- Maximum permitted pressure drop
- Available steam pressure

M6

Typical capacities

Liquid flow rate

Up to 16 kg/s (250 gpm), depending on media, permitted pressure drop and temperature program.

Water heating by steam

300 to 800 kW

Plate types

M6, M6M, M6MD and M6MG

Frame types

FM, FG and FD

Standard Materials

Frame plate

Mild steel, Epoxy painted

Nozzles

Carbon steel

Metal lined: Stainless steel, Titanium

Rubber lined: Nitrile, EPDM

Plates

Stainless steel: Alloy 316 / Alloy 304

Titanium (M6M only)

Gaskets

M6: Nitrile, EPDM, HeatSeal F™

M6M: Nitrile, EPDM, HeatSeal F™

Technical Data

Pressure vessel codes, PED, ASME, pvcALS™

Mechanical design pressure (g) / temperature

FM	pvcALS™	1.0 MPa / 160°C
FG	PED	1.6 MPa / 180°C *)
FG	ASME	150 psig / 320°F
FG	pvcALS™	1.6 MPa / 180°C
FD	PED, pvcALS™	2.5 MPa / 160°C
FD	ASME	300 psig / 320°F

*) Frame FG also approved for 1.2 MPa/200°C to allow use in steam systems without safety valves.

Maximum heat transfer surface

390 m² (4,200 sq. ft)

Connections

Pipe connections (not for frame type FD)

Straight threaded	Size 50 mm	ISO G2", NPT 2"
Straight weld	Size 50 mm	
Threaded inlet port	Size 50 mm	ISO G2"

Flange connections

FM	pvcALS™	Size 50 mm	DIN/GB/GOST PN10, ASME Cl. 150
FG	PED	Size 50 mm	DIN 2501 PN16, ASME Cl. 150
FG	ASME	Size 2"	ASME Cl. 150
FG	pvcALS™	Size 50 mm	DIN/GB/GOST PN16, ASME Cl. 150
FD	PED	Size 50 mm	DIN 2501 PN25, ASME Cl. 30
FD	ASME	Size 2"	ASME Cl. 300

Dimensions

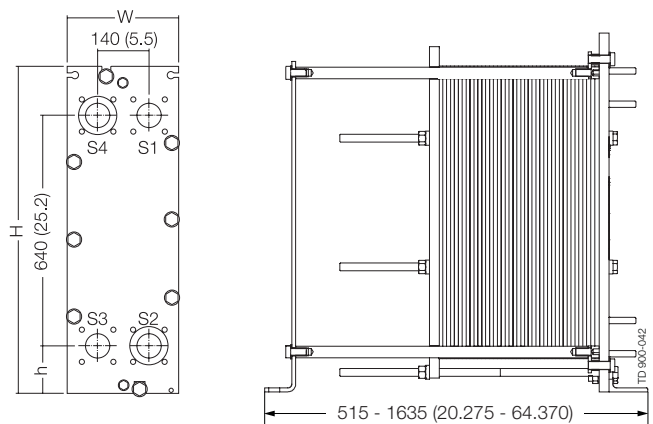

Measurements mm (inch)

Type	H	W	h
M6-FM	920 (367/32)	320 (125/8)	140 (5½)
M6-FG	920 (367/32)	320 (125/8)	140 (5½)
M6-FD	940 (37)	330 (125/8)	150 (6)

The number of tightening bolts may vary depending on pressure rating.

Particulars required for quotation

- Flow rates or heat load
- Temperature program
- Physical properties of liquids in question (if not water)
- Desired working pressure
- Maximum permitted pressure drop
- Available steam pressure

M10

Typical capacities

Liquid flow rate

Up to 50 kg/s, depending on media, permitted pressure drop and temperature program.

Water heating by steam

0.7 to 3.0 MW

Plate Types

M10B, M10M and M10MD

Frame Types

FM, FG and FD

Standard Materials

Frame plate

Mild steel, Epoxy painted

Nozzles

Carbon steel

Lined: Stainless steel, Rubber, Titanium

Plates

Stainless steel AISI 316/AISI 304, Titanium, Alloy 20/18/6

Gaskets

M10B Nitrile, EPDM

M10M Nitrile, EPDM, HeatSeal F™, HNBR, EPDMF, Viton®G

Technical data

Mechanical design pressure (g) / temperature

FM	1.0 MPa / 160°C
FG	1.6 MPa / 180°C *)
FG ASME	150 psig / 350°F
FD	2.5 MPa / 160°C
FD ASME	300 psig / 320°F

*) Frame FG also approved for 1.2 MPa / 200°C to allow use in steam systems without safety valves.

Maximum heat transfer surface

M10B: 90 m² (970 sq. ft)

M10M: 60 m² (650 sq. ft)

Connections

FM – Size 100 mm	DIN 2501 PN10 or ANSI 150
FG – Size 100 mm	DIN 2501 PN16 or ANSI 150
FD – Size 100 mm	DIN 2501 PN25 or ANSI 150
FD – Size 100 mm	DIN 2501 PN25 or ANSI 300 (ASME)

Dimensions

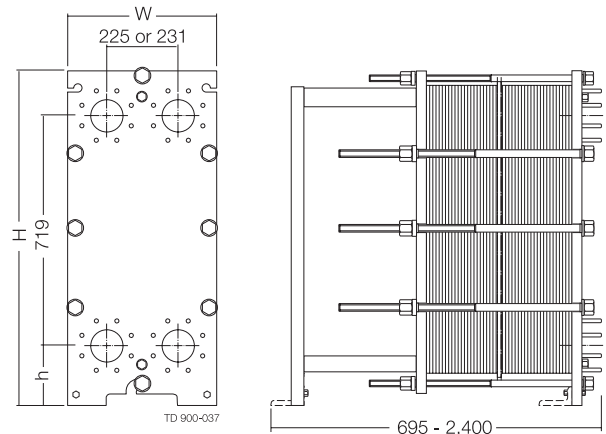

Measurements (mm)

Type	H	W	h
M10-FM	1.084	470	215
M10-FG	1.084	470	215
M10-FD	981	470	131
M10-FD ASME	1.084	470	215

The number of tightening bolts may vary depending on pressure rating.

Particulars required for quotation

- Flow rates or heat load
- Temperature program
- Physical properties of liquids in question (if not water)
- Desired working pressure
- Maximum permitted pressure drop
- Available steam pressure

M15

Typical Capacities

Liquid flow rate

Up to 80 kg/s (1,300 gpm), depending on media, permitted pressure drop and temperature program.

Plate types

M15B, M15E and M15M

Frame typ

FL, FM, FG and FD

Standard Materials

Frame plate

Mild steel, Epoxy painted

Nozzles

Carbon steel

Metal lined: Stainless steel, Titanium

Rubber lined: Nitrile, EPDM

Plates

Stainless steel: Alloy 304, Alloy 316

Titanium

Alloy C-276

Alloy 254 SMO

Gaskets (Clip-on/Tape-on, Glued)

Nitrile Nitrile hydrogenated

EPDM Viton® G

AL-EPDM

Technical Data

Pressure vessel codes, PED, ASME, pvcALS™

Mechanical design pressure (g) / temperat

FL	pvcALS™	0.6 MPa / 130°C
FM	PED, pvcALS™	1.0 MPa / 180°C
FG	PED, pvcALS	1.6 MPa / 180°C
FG	ASME	150 psig / 350°F
FD	PED, pvcALS™	3.0 MPa / 180°C
FD	ASME	300 psig / 350°F

Maximum heat transfer surface

390 m² (4,200 sq. ft)

Connections

FL	pvcALS™	Size 150 mm	DIN/GB/GOST PN10, ASME Cl. 150, JIS 10K
FM	PED	Size 150 mm	DIN 2501 PN16, ASME Cl. 150
FM	pvcALS™	Size 150 mm	DIN/GB/GOST PN10, ASME Cl. 150, JIS 10K
FG	PED	Size 150 mm	DIN 2501 PN16, ASME Cl. 150
FG	pvcALS™	Size 150 mm	DIN/GB/GOST PN16, ASME Cl. 150, JIS 16K
FG	ASME	Size 6"	ASME Cl. 150
FD	PED	Size 150 mm	DIN 250 PN25, ASME Cl. 300
FD	ASME	Size 6"	ASME Cl. 300

Dimensions

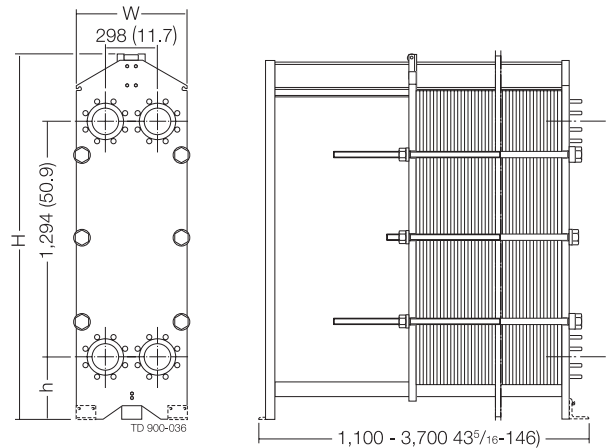

Measurements mm (inch)

Type	H	W	h
M15-FL	1,815 (71½)	610 (24)	275 (10¾)
M15-FM	max. 1,941 (76½)	610 (24)	275 (10¾)
M15-FG	max. 1,941 (76½)	650 (25½)	275 (10¾)
M15-FD	max. 2,036 (80)	650 (25½)	370 (14½)

The number of tightening bolts may vary depending on pressure rating.

Particulars required for quotation

- Flow rates or heat load
- Temperature program
- Physical properties of liquids in question (if not water)
- Desired working pressure
- Maximum permitted pressure drop
- Available steam pressure