



The premium ex Pump

LKHex Centrifugal Pump

Applications

The LKHex pump is a highly efficient and economical centrifugal pump, which meets the requirements of the ATEX directive 94/9 IEC group II, categories 2 and 3, temperature class T3 and T4. LKHex is available in nine sizes, LKHex-10, -15, -20, -25, -35, -40, -45, -50, -60.

The LKHex performance data are equal to the performance of LKH pump.

Standard design

The LKHex pump consists of motor, stub shaft, mechanical compression coupling, adaptor, back plate, impeller, pump casing and shaft seal.

The LKHex has a stainless steel shroud for protection of the motor, and the complete unit is supported on four adjustable stainless steel legs.

Shaft seals

The LKH pump is equipped with either a single shaft seal or a double mechanical shaft seal. The seal ring is in acid-resistant steel AISI 329 with sealing surface in silicon carbide and rotating seal rings in carbon or silicon carbide.

Materials

Product wetted steel parts: Acid-resistant steel 1.4404 (316L).

Other steel parts: Stainless steel 1.4301 (304).

Finish: Semi bright.

Product wetted seals: EPDM, NBR, FPM and FEP.

Technical data

Max. inlet pressure: LKHex (50/60 Hz): 1000 kPa (10 bar).

Product temperature (T4): -10°C to +80°C (NBR).
-10°C to +110°C (EPDM, FPM, FEP).

Product temperature (T3): -10°C to +80°C (NBR).
-10°C to +110°C (EPDM).
-10°C to +140°C (FPM, FEP).

Ambient temperature: -10°C to +30°C

Double mechanical shaft seal (DMS):

Water pressure inlet, LKH-10 to -60: Max. 500 kPa (5 bar).

Water consumption: 0.25 -0.5 l/min.

Connections for DMS:

R 1/8" (BSP) external thread.



LKHex- 10 with shroud and legs

Motor

Foot-flanged ATEX approved motor according to the IEC metric standard, 2 poles = 3000/3600 rpm. at 50/60 Hz.

Voltage and frequency

50 Hz	EEEx d & EEEx d(e)	230V Δ/400VY	≤ 7.5 kW
	EEEx d & EEEx d(e)	400V Δ/690VY	≥ 11 kW
60 Hz	EEEx d & EEEx d(e)	440-480VY	≤ 7.5 kW
	EEEx d & EEEx d(e)	440-480V Δ	≥ 11 kW
50 Hz	EEEx e	220-240V Δ/380-420VY	≤ 4 kW
	EEEx e	380-400V Δ	≥ 5.5 kW
60 Hz	EEEx e	440-480V Y	≤ 4 kW
	EEEx e	440-460V Δ	≥ 5.5 kW

Motor sizes

50 Hz: 1.5 - 2.2 - 3 - 4 - 5.5 - 7.5 - 11 - 15 - 18.5 - 22 kW.

60 Hz: 1.75 - 2.5 - 3.5 - 4.6 - 6.4 - 8.6 - 12.5 - 17 - 21 - 25 kW.

Dimensions

Note that most of the dimensions depend on motor supplier and motor size. Non-dependent dimensions are equal to the dimensions for LKH.

Dimensions (mm)

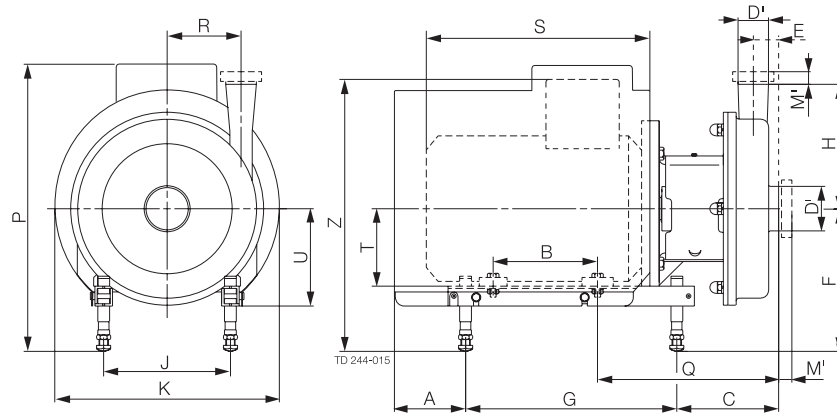

LKHex-10

Size	Motor			
	1.5 kw	2.2 kw	3 kw	4 kw
	EEX d / EEX e / EEX d(e)			
A	164/139/164	164/139/164	104/78/104	105/81/105
B	100	125	140	140
C	132	132	140	147
E	23	23	23	23
F min.	189	189	185	184
F max.	275	275	295	297
G	272	272	320	320
H	142	142	142	142
J	140	140	160	190
K	288	288	323	359
P min.	427/346/427	427/346/427	423/357/423	434/383/434
P max.	513/432/513	513/432/513	533/467/533	547/496/547
Q	215	215	235	242
T	90	90	100	112
R	87	87	87	87
S	318	318	340	348
U	125	125	145	147
Z min.	416/316/379	416/316/379	412/321/375	423/330/386
Z max.	502/402/465	502/402/465	522/431/485	536/443/499
Weight (kg)	*	*	*	*f

LKHex-15

Size	Motor		
	3 kw	4 kw	5.5 kw
	EEX d / EEX e / EEX d(e)		
A	104/78/104	105/81/105	139/81/139
B	140	140	178
C	176	183	181
E	43	43	43
F min.	185	184	184
F max.	295	297	317
G	320	320	400
H	166	166	166
J	160	190	216
K	323	359	383
P min.	423/357/423	434/383/434	449/380/449
P max.	533/467/533	547/492/547	567/513/567
Q	271	278	316
R	66	66	66
S	340	348	440
T	100	112	132
U	145	147	167
Z min.	412/321/375	423/330/386	438/348/414
Z max.	522/431/485	536/443/499	571/481/547
Weight (kg)	*	*	*

LKHex-20

Size	Motor				
	1.5 kw	2.2 kw	3 kw	4 kw	5.5/7.5 kw
	EEX d / EEX e / EEX d(e)				
A	164/139/164	164/139/164	104/78/104	105/81/105	139/81/139
B	100	125	140	140	178
C	145	145	152	159	157
E	27	27	27	27	27
F min.	189	189	185	184	184
F max.	275	275	295	297	317
G	272	272	320	320	400
H	180	180	180	180	180
J	140	140	160	190	216
K	288	288	323	359	383
P min.	427/346/427	427/346/427	423/347/423	434/383/434	449/380/449
P max.	513/432/513	513/432/513	533/467/533	547/496/547	582/513/582
Q	227	227	247	254	292
R	88	88	88	88	88
S	318	318	340	348	440
T	90	90	100	112	132
U	125	125	145	147	167
Z min.	416/316/379	416/316/379	412/321/375	423/330/386	438/348/414
Z max.	502/402/465	502/402/465	522/431/485	536/443/499	571/481/547
Weight (kg)	*	*	*	*	*

LKHex-25

Size	Motor	
	5.5/7.5 kw	11/15 kw
	EEX d / EEX e / EEX d(e)	
A	139/81/139	164/105/164
B	178	210
C	163	192
E	32	32
F min.	184	228
F max.	317	345
G	400	483
H	193	193
J	216	254
K	383	485
P min.	449/380/449	569/490/569
P max.	582/513/582	686/607/686
Q	298	345
R	106	106
S	440	549
T	132	160
U	167	195
Z min.	438/348/414	558/438/539
Z max.	571/481/547	675/554/656
Weight (kg)	*	*

900261/1

Dimensions (mm)

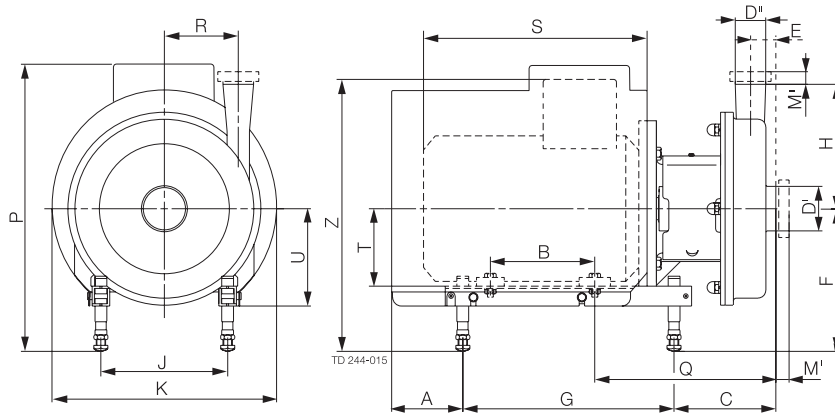

LKHex-35

Size	Motor		
	4 kw	5.5/7.5 kw EEEX d / EEEX e / EEEX d(e)	11/15 kw
A	105/81/105	139/81/139	164/105/164
B	140	178	210
C	150	148	177
E	23	23	23
F min.	184	184	228
F max.	297	317	345
G	320	400	483
H	193	193	193
J	190	216	254
K	359	383	485
P min.	434/383/434	449/380/449	569/490/569
P max.	547/496/547	582/513/582	686/607/686
Q	245	283	330
R	119	119	119
S	348	440	549
T	112	132	160
U	147	167	195
Z min.	423/330/386	438/348/414	558/438/539
Z max.	536/443/499	571/481/547	675/554/656
Weight (kg)	*	*	*

LKHex-40

Size	Motor		
	7.5 kw	11/15/18.5 kw EEEX d / EEEX e / EEEX d(e)	22 kw
A	139/81/139	164/105/164	198/156/198
B	178	210	241
C	158	187	201
E	28	28	28
F min.	184	228	260
F max.	317	345	365
G	400	483	508
H	212	212	212
J	216	254	279
K	383	485	533
P min.	449/380/449	569/490/569	601/546/601
P max.	582/513/582	686/607/686	706/671/706
Q	293	340	353
R	126	126	126
S	440	549	617
T	132	160	180
U	167	195	215
Z min.	438/348/414	558/438/539	590/484/571
Z max.	571/481/547	675/554/656	695/589/676
Weight (kg)	*	*	*

LKHex-45

Size	Motor		
	4 kw	5.5/7.5 kw EEEX d / EEEX e / EEEX d(e)	11/15 kw
A	105/81/105	139/81/139	164/105/164
B	140	178	210
C	179	177	206
E	41	41	41
F min.	184	184	228
F max.	297	317	345
G	320	400	483
H	193	193	193
J	190	216	254
K	359	383	485
P min.	434/383/434	449/380/449	569/490/569
P max.	547/496/547	582/513/582	686/607/686
Q	274	312	359
R	97	97	97
S	348	440	549
T	112	132	160
U	147	167	195
Z min.	423/330/386	438/347/414	558/438/539
Z max.	536/443/499	571/480/547	675/554/656
Weight (kg)	*	*	*

LKHex-50

Size	Motor		
	5.5/7.5 kw	11/15/18.5 kw EEEX d / EEEX e / EEEX d(e)	22 kw
A	139/81/139	164/105/164	198/156/198
B	178	210	241
C	171	200	213
E	35	35	35
F min.	184	228	260
F max.	317	345	365
G	400	483	508
H	205	205	205
J	216	254	279
K	383	485	534
P min.	449/380/449	569/490/569	601/546/601
P max.	582/513/582	686/607/686	706/671/706
Q	306	353	366
R	118	118	118
S	440	549	617
T	132	160	180
U	167	195	215
Z min.	438/348/386	558/438/539	590/484/571
Z max.	571/481/547	675/554/656	695/589/676
Weight (kg)	*	*	*

900261/1

Dimensions (mm)

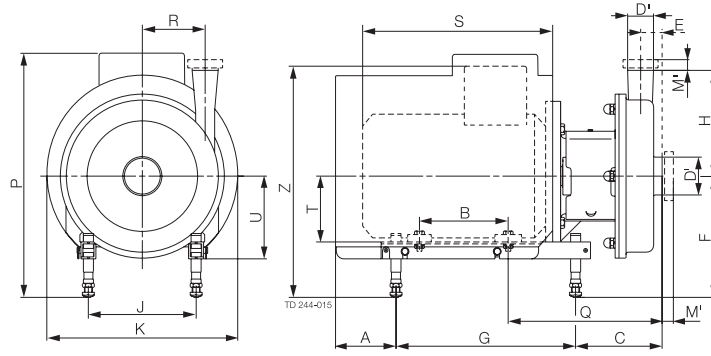

LKHex-60

Size	Motor		
	5.5/7.5 kw	11/15/18.5 kw	22 kw
	EEX d / EEX e / EEX d(e)		
A	139/81/139	164/105/164	198/156/198
B	178	210	241
C NW150	250	279	292
C 4"	200	229	242
C clamp 6"	240	269	282
E NW150	112	112	112
E 4"	62	62	62
E clamp 6"	102	102	102
F min.	184	228	260
F max.	317	345	365
G	400	483	508
H	262	262	262
J	216	254	279
K	383	485	534
P min.	449/380/449	569/490/569	601/546/601
P max.	582/513/582	686/607/686	706/671/706
Q NW150	385	432	445
Q 4"	335	382	395
Q clamp 6"	375	422	435
R	102	102	102
S	440	549	617
T	132	160	180
U	167	195	215
Z min.	438/348/414	558/437/539	590/484/571
Z max.	571/481/547	675/554/656	695/589/676
Weight (kg)	-	-	-

LKHex-20

D ⁱ	NW65
D ^o	NW50
M ⁱ	46.7
M ^o	21.5

LKHex-25

D ⁱ	76mm
D ^o	60.3mm
M ⁱ	50
M ^o	90.1

LKHex-45

D ⁱ	NW100
D ^o	NW80
M ⁱ	64
M ^o	64

LKHex-50

D ⁱ	114.3mm
D ^o	76.1mm
M ⁱ	50
M ^o	71.3

LKHex-60

D ⁱ	NW150
D ^o	NW100
M ⁱ	105.6
M ^o	64

Connections (mm) Sanitary version

LKHex-10, -20, -35

D ⁱ : 63.5	ISO	ISO	DIN	SMS	BS	DS
D ^o : 51	Clamp	Male	Male	Male	Male	Male
M ⁱ	21	21	25	24	27	24
M ^o	21	21	22	20	27	20

LKHex-15, -45, -50

D ⁱ :101.6	ISO	ISO	DIN	SMS	BS	DS
D ^o :76.1	Clamp	Male	Male	Male	Male	Male
M ⁱ	21	21	30	35	32	24
M ^o	12	21	30	24	27	24

LKHex-25

D ⁱ :76.1	ISO	ISO	DIN	SMS	BS	DS
D ^o : 63.5	Clamp	Male	Male	Male	Male	Male
M ⁱ	21	21	30	24	27	24
M ^o	21	21	25	24	27	24

LKHex-60

D ⁱ :101.6	ISO	ISO	DIN	SMS	BS	DS
D ^o :101.6	Clamp	Male	Male	Male	Male	Male
M ⁱ	21	21	30	35	32	24
M ^o	21	21	30	35	32	24

LKHex-40

D ⁱ :76.1	ISO	ISO	DIN	SMS	BS	DS
D ^o :63.5	Clamp	Male	Male	Male	Male	Male
M ⁱ	21	21	30	24	27	24
M ^o	12	21	27	24	22	21

LKHex-60

D ⁱ :DN150	DIN	D ⁱ : 6"	ISO
D ^o :DN100	Male	D ^o : 4"	Clamp
M ⁱ	50	M ⁱ	38
M ^o	30	M ^o	16

900261/0

Flow chart

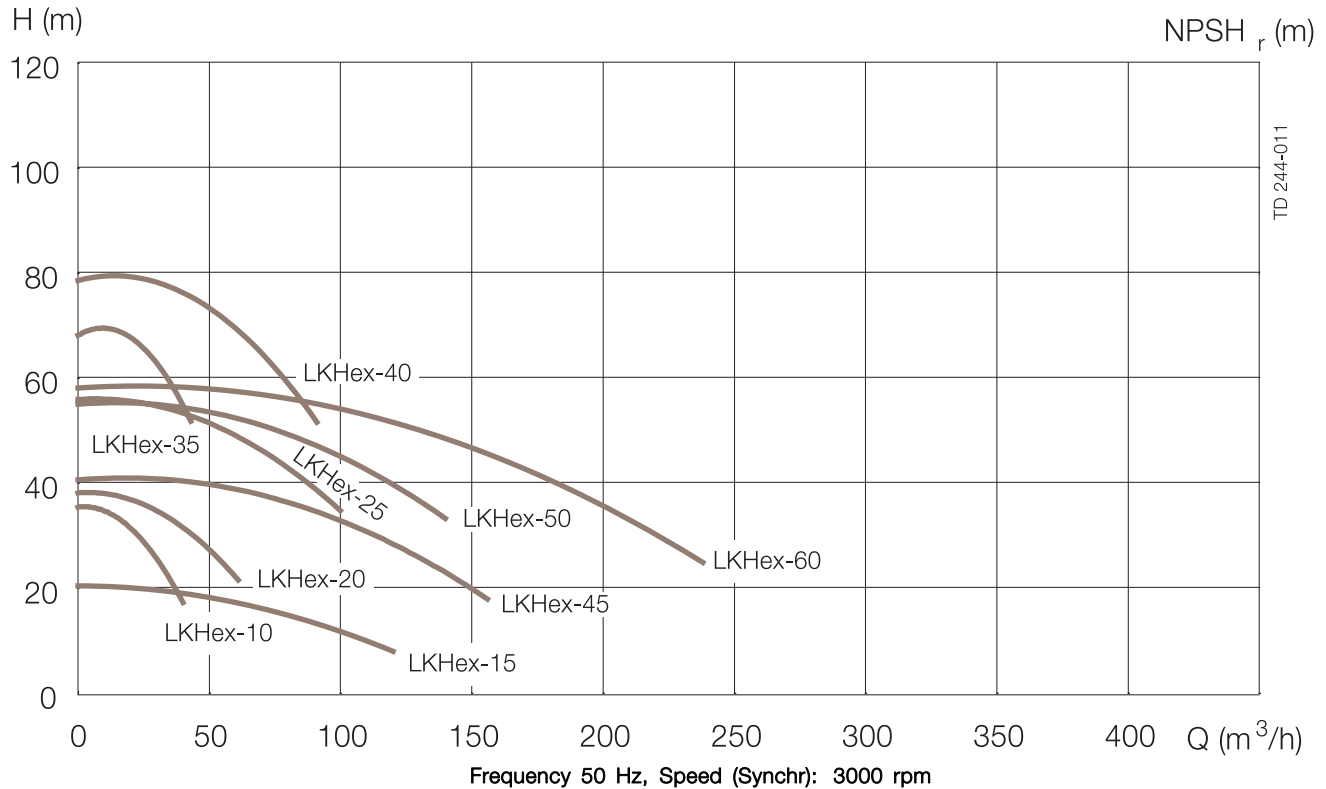

Options

- A. Impeller with reduced diameter.
- B. Motor for other voltage and/or frequency.
- C. 1500 rpm. motor.
- D. Counter flanges, seal rings and bolts for flanged connections (industrial version).
- E. Wider clearance between impeller and backplate if there is a risk of building up a hard layer of product. (Standard clearance is 0.5 mm and can be made up to 2.5 mm).
- F. Surface roughness, product wetted parts:
 $R_a \leq 0.8 \mu\text{m}$.
- G. Product wetted seals of Nitrile (NBR), Fluorinated rubber (FPM) or FEP.
- H. Rotating seal ring of Silicon Carbide.

Ordering

Please state the following when ordering:

- Pump size.
- Connections.
- Impeller diameter.
- Motor size.
- Voltage and frequency.
- Flow, pressure, ambient and media temperature.
- Atmosphere ignition temperature.
- Group category and temperature class.
- Density and viscosity of the product.
- With or without shroud.
- Shaft seal material.

Note!

For further details, see also IM 70969.

This product has EHEDG certification.
This product is compliant with the ATEX directive.