



# HEATPAC®

## EHS-61, -62 Electric Heating Systems

### Application

The HEATPAC Electric Heating Systems are specifically designed for the heating of mineral oils in booster systems and prior to centrifugal cleaning.

The HEATPAC Systems are type-approved by ABS, BV, DnV, GL, LR, NK, RINA, RMRS.

### Concept

The HEATPAC EHS System (Fig. 2) comprises:

- Heater EHM.
- HEATPAC control unit (EHS-61 only).
- HEATPAC power unit (EHS-62 only).
- Ancillary equipment including PT-100 temperature sensor, high temperature sensor and safety valve.

### Features

The unique features of the HEATPAC System are:

- Compact and lightweight design.
- Incremental electronic temperature control.
- Specially designed heating elements for high-efficiency heat transfer.
- Fully automatic operation.

### Benefits

The main benefits include:

- Ease of installation.
- Instant temperature control. Temperature accuracy to within  $\pm 1^{\circ}\text{C}$ .
- Gentle treatment. No deterioration of heated oil.
- Start-and-forget operation.
- Optimum heating of all types of mineral oils, particularly high-density, high-viscosity fuel oils, sensitive lubricating oils and turbine oils.

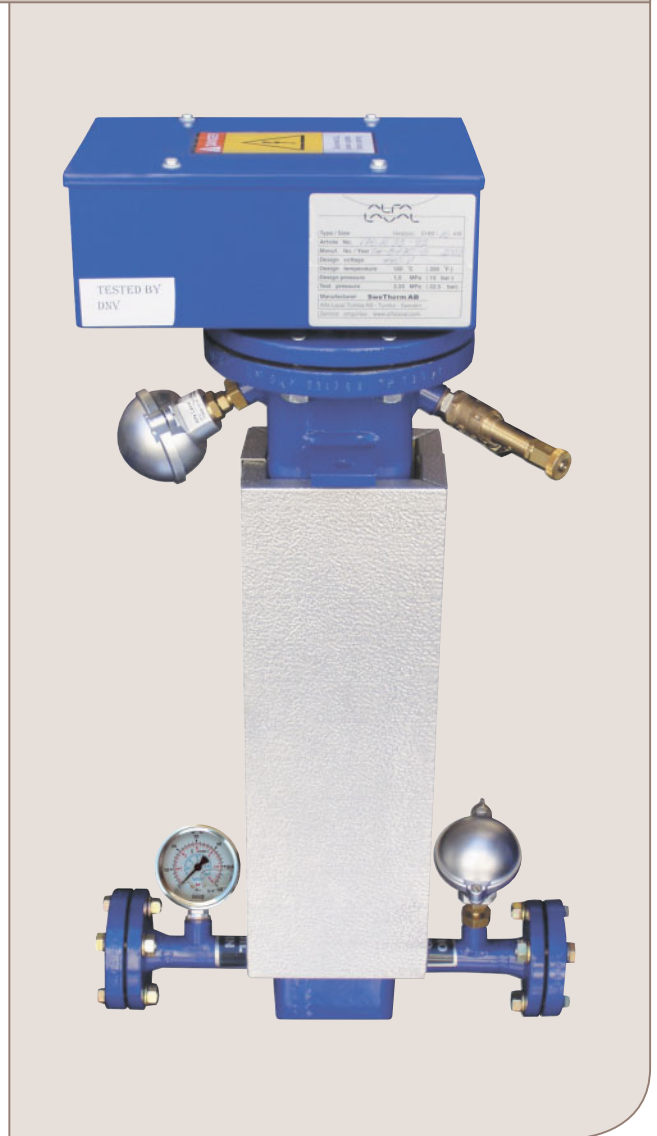

Fig. 1. EHM Electric Heater with ancillaries.

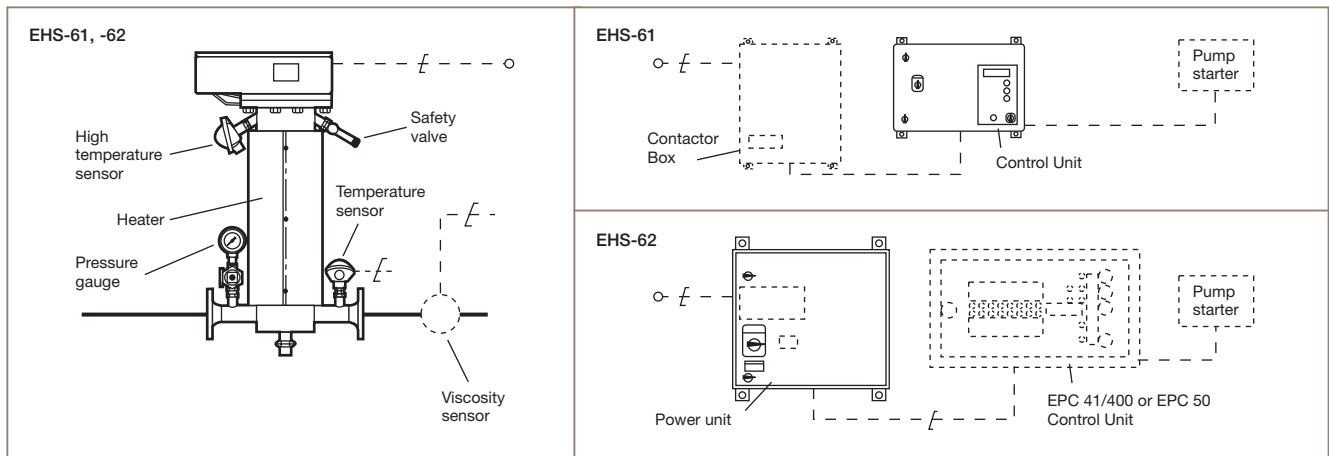

Fig. 2. Basic concept of the HEATPAC EHS System.

**System working principle**

The fuel or lubricating oil is fed continuously to the HEATPAC heater. A signal from the Pt-100 temperature sensor at the oil outlet is transmitted to the HEATPAC control unit (EHS-61) or external controller, such as an EPC-41/400 or EPC 50 (EHS-62) which regulates the amount of electric power to the heating elements. Heat is transferred to the oil through the corrugated aluminium surface. (Fig. 3).

Overall incremental operation is automatically controlled by the HEATPAC control unit or the external controller. The HEATPAC control unit and power unit features specially designed thyristor modules which perform the incremental feeding of power and prevent any interference with other shipboard electric and electronic equipment. A unique characteristic of the cast aluminium heating elements is the rapid response to any load change. This feature, in combination with the specially designed control system, ensures outstanding control performance, independent from any fluctuations in flow rate or oil temperature.

Standard safety equipment comprises a high temperature sensor located in close proximity to the aluminium heating element. (The high temperature sensor cooperates with an independent temperature guard in the control unit / power unit to ensure protection from overheating.) Further the heater automatically turns off if the pump starter is turned off. This feature ensures that the heater is fully protected from overheating in the event of a systems operations failure.

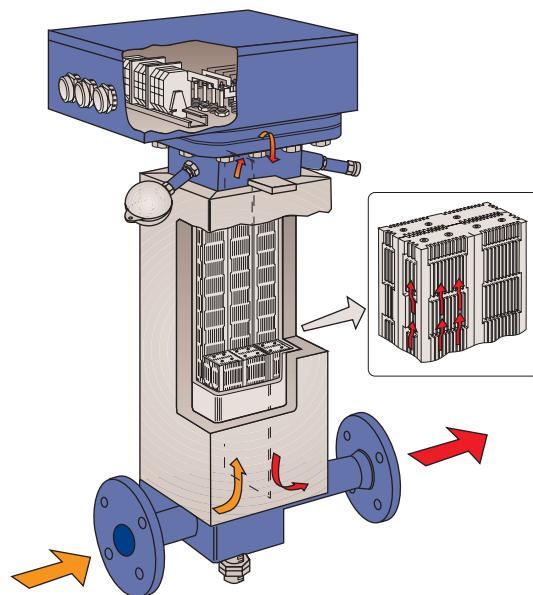

Fig. 3. Working principle of the HEATPAC System.

**Heater capacity**

The actual capacity depends on temperature increase and flow rate. Six sizes are available, from 7 to 72 kW. The power loads for each size are shown in Fig. 4.

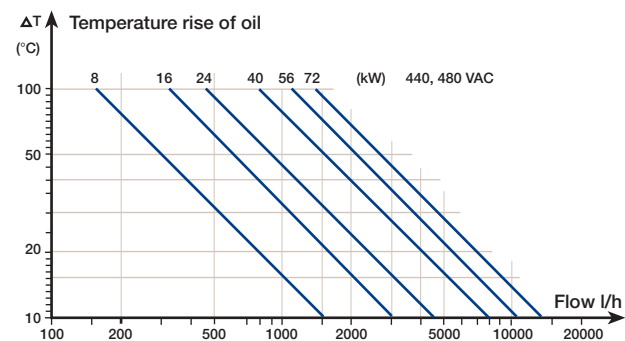
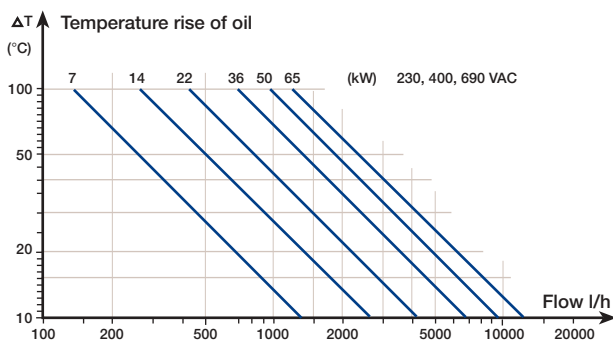

Fig. 4. Size chart and power loads based on temperature and flow rate (not for dimensioning).

## Main system components

### HEATPAC EHM Heater, standard design

The heater comprises rectangular diecast aluminium heating elements mounted on a flange to form a compact heating block which is inserted in a pressure vessel made of mild steel. A baffle inside the vessel divides the flow into two passes. The oil inlet and outlet are located opposite each other on the same level, enabling installation in a series.

The terminal box housing at the top of the heater is separated from the hot pressure vessel to maintain a low temperature in the box. The hot side of the pressure vessel is adequately insulated with 25-mm mineral wool wrapped in aluminium sheet.

#### Technical data

Design pressure:	1.5 MPa (15 bar)
Test pressure:	2.25 MPa (22 bar)
Max. temperature:	160°C
Power supply:	230, 400, 440, 480, 690 VAC, 50/60 Hz

### HEATPAC control unit (EHS-61 systems), standard design

The control unit, housed in a robust cabinet, comprises a control module, two thyristor modules and contactors for feeding electric power to the heater. The control module contains the essential plant-dependent parameters and a PI regulating function.

The front panel is equipped with power switch and mode-selection switch, alarm lamp push button, three push buttons for setting of parameters, and a sectional display window indicating current temperature. Six light-emitting diodes behind the display window clearly indicate mode of operation and alarm signals. Values and codes for alarm identification are shown on the panel. The control unit can be linked to a remote computer in the control room through a current-loop interface.

#### Technical data

##### EPC 50

Operating voltage:	24 VAC
Power supply:	400, 440, 480, 690 VAC 50/60 Hz
Dimensions:	≤24 kW: H/540, W/550, D/260 36–72 kW: H/730, W/550, D/320
Max. ambient temperature:	55°C
Protection class:	IP65
Weight:	40 kg

##### EPC 41/400

Operating voltage:	48 VAC
Power supply:	230, 400, 440, 480 VAC 50/60 Hz
Dimensions:	≤24 kW: H/540, W/550, D/260 36–72 kW: H/730, W/550, D/320
Max. ambient temperature:	55°C
Protection class:	IP65
Weight:	40 kg

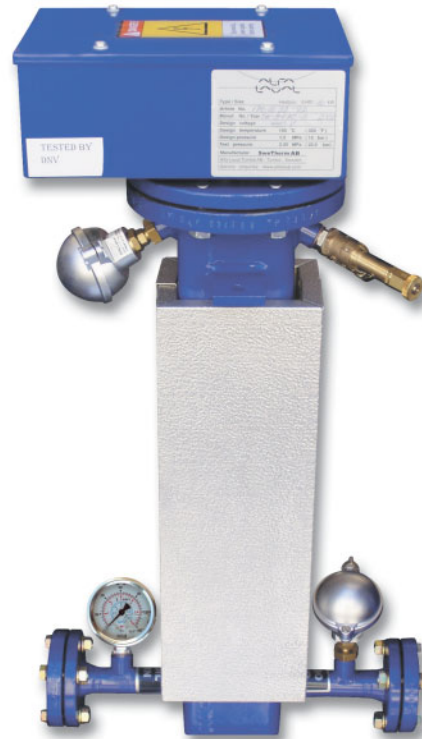

Fig. 5. HEATPAC EHM Heater.

### HEATPAC power unit (EHS-62 systems)

The power unit, housed in a robust cabinet, comprises two thyristor modules, contactors and overcurrent protection for feeding electric power to the heater.

For operation it depends on an external controller, i.e., the separation systems EPC.

There are two cabinet sizes, one up to 24 kW and the other for 36–72 kW, and two design lines, one with operating voltage 48 VAC (for EPC 41/400 as controller) and one with 24 VAC (for EPC 50 as controller).

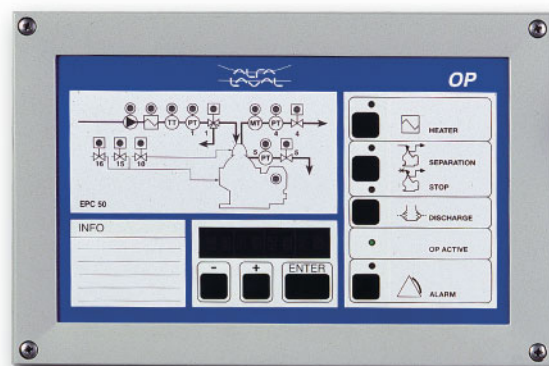

Fig. 6. EPC 50 operating panel.

**Contacting box**

For sizes bigger than 22/24 kW an additional contacting box is required in the system for feeding of base load.

The contacting box is only used with the HEATPAC control unit.

**Technical data**

Power supply:	230, 400, 440, 480 VAC, 50/60 Hz
Contactors:	48 VAC
Control module internal voltage:	48 V, 20 V, 10 V
Dimensions (mm):	H/450, W/550, D/260
Weight (kg):	40
Protection class:	IP 65
Max. ambient temperature:	55°C
External inputs:	48 VAC potential-free contact Pt-100 three-wire measurement 4–20 mA
External outputs:	function alarm process alarm external contactor

**Installation**

The HEATPAC heater can be installed in any position. All system components are designed for on-site installation in the engine room. Flanges are according to DIN standard. JIS standard upon request.

Type kW	Dimensions (mm)			Connections		Weight kg
	A	B	C	mm	inch	
EHM 7/8	890	366	185	25	1	29
EHM 14/16	890	394	220	25	1	39
EHM 22/24	895	460	300	40	1.5	61
EHM 36/40	895	460	300	40	1.5	76
EHM 50/56	895	460	300	40	1.5	106
EHM 65/72	895	460	344	40	1.5	131

All sizes are available for 230, 400, 440, 480, and 690 V.

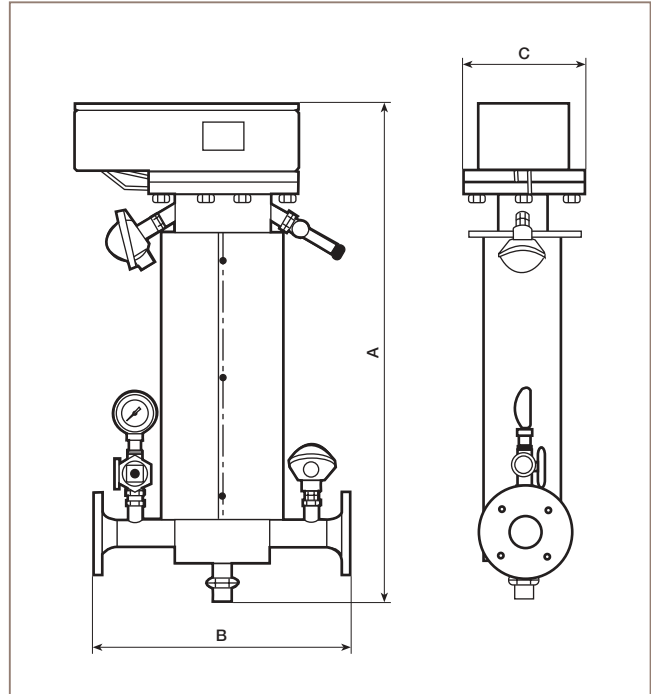

Fig. 7. Dimensional drawing heater.

**Technical documentation**

Complete information and documentation is provided in the Instruction Book (IB) accompanying each HEATPAC delivery.

**Service support**

An international network of Alfa Laval Service Centres provides the security of spares and service wherever you are.

Our service engineers will be pleased to assist you with any level of maintenance and will train your operation and maintenance personnel, if desired.

Further information can be obtained from your local Alfa Laval representative.

**How to contact Alfa Laval**

Contact details for all countries are continually updated on our web site. Please visit [www.alfalaval.com](http://www.alfalaval.com) to access the information direct.