



Fuel oil filter – F-152 range

Continuously automatic backflushing fuel oil filter

The F-152 automatic filter range provides full-flow fine filtration of heavy fuel oil (HFO) up to 700 cSt/50°C. Developed to cover all the requirements of modern two- and four-stroke engines, the F-152 requires minimal investment yet delivers highly reliable operation and true peace of mind.

Unique features

- Robust disc-type filter elements.
- Continuous backflushing driven by the filtered oil.
- Constant pressure drop across the filter.
- Filtered oil drives the backflushing process.
- Compact and lightweight.
- Cleaning of the backflushed oil by refiltration in the diversion chamber before recirculation in the system.
- Removal of particles collected from the system at the filter.

Key benefits

- Robust design reduces risk of the filter element cracking.
- Continuous backflushing significantly prevents adhesion of retained solids to filter surfaces, which results in:
 - No manual cleaning of filter elements.
 - Low and constant pressure drop across the filter elements, which further reduces the risk of cracking.
- Use of filtered oil for the backflushing process eliminates the need for compressed air.
- Installation is recommended on the circulation side (hot loop) of the fuel oil system for maximum engine protection. The robust design and elimination of colder backflush media prevents thermal shock which can result in the formation of asphaltenes.
- Constant pressure drop across the filter, combined with the pressure drop indicator, facilitates the detection of a malfunction in the fuel oil system.
- Cleaning of backflushed flow enables recirculation of fuel and reduces sludge volume to a minimum.



Automatic fuel oil filter shown with electrical motor.

- It is easy to install in new fuel oil systems and to retrofit existing ones.
- There is no need for a sludge treatment unit (consumable item or manual cleaning system). The diversion chamber acts as an automatic maintenance-free sludge treatment system, collecting particles backflushed from the full-flow chamber and cleaning itself to concentrate sludge.

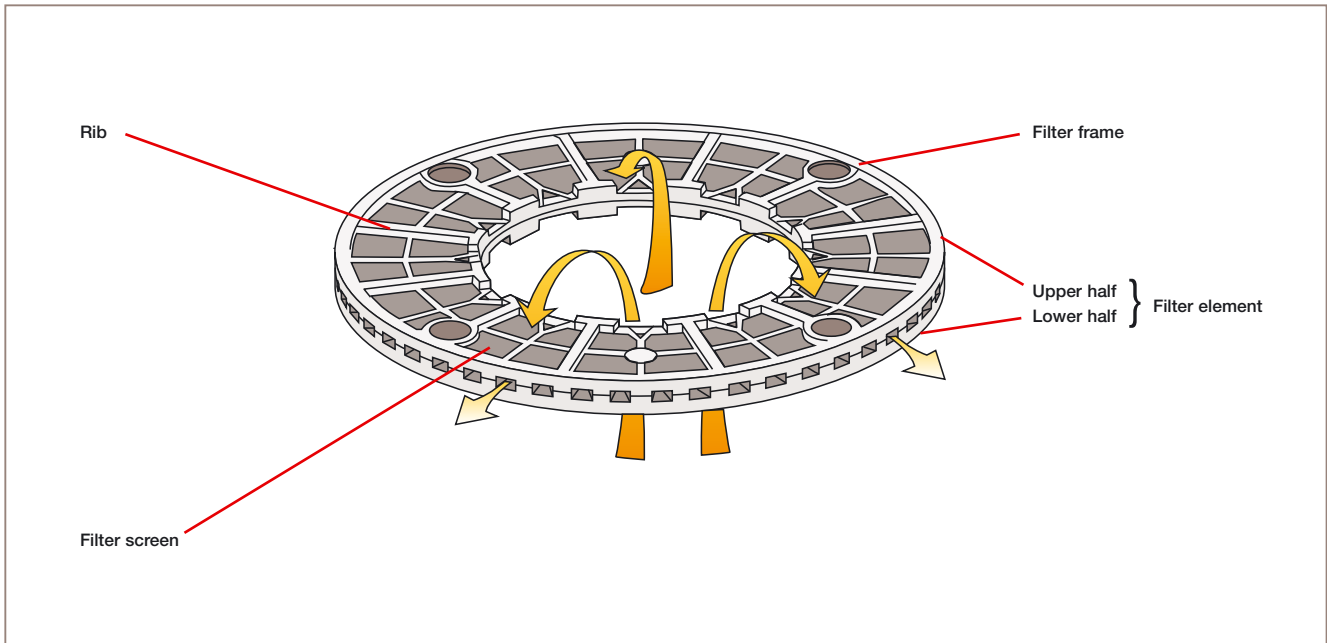

Figure 1. Full-flow element.

Diesel engine protection

The fuel oil conditioning system includes filters to remove solid particles that may have entered the system after the separator, which is installed in the cleaning system. The filter therefore prevents any potentially dangerous particles from reaching the sensitive parts of the diesel engine fuel system. To guarantee 100% full-flow protection, the filter should be installed as close to the engine as possible.

Distributor drive

The distributor, which creates the backflushing and self-cleaning effect of the filter, is driven by an electric motor. The shape of the distributor is optimized to provide the best possible cleaning efficiency, which results in longer periods of time between maintenance intervals.



Figure 2. Distributor.

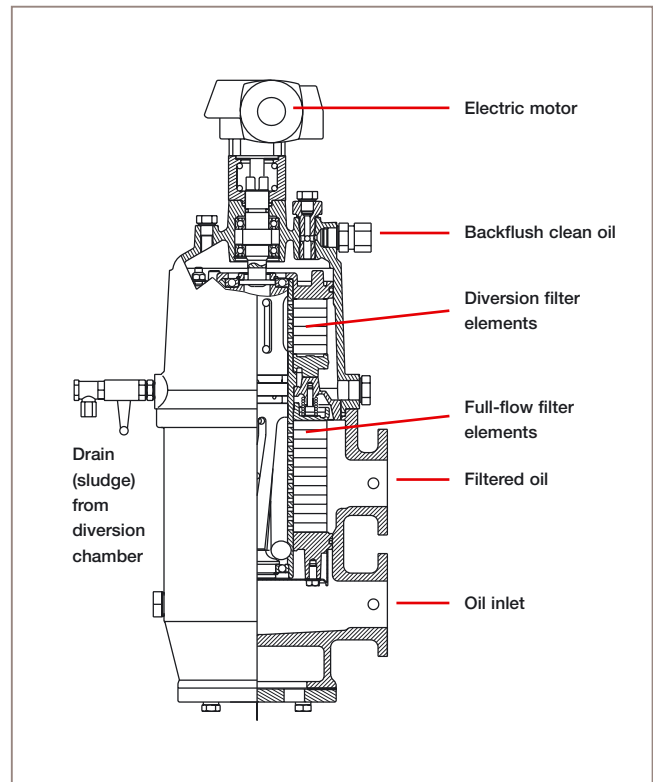

Figure 3. Fully assembled filter showing full-flow and diversion chamber filter elements and electric motor.

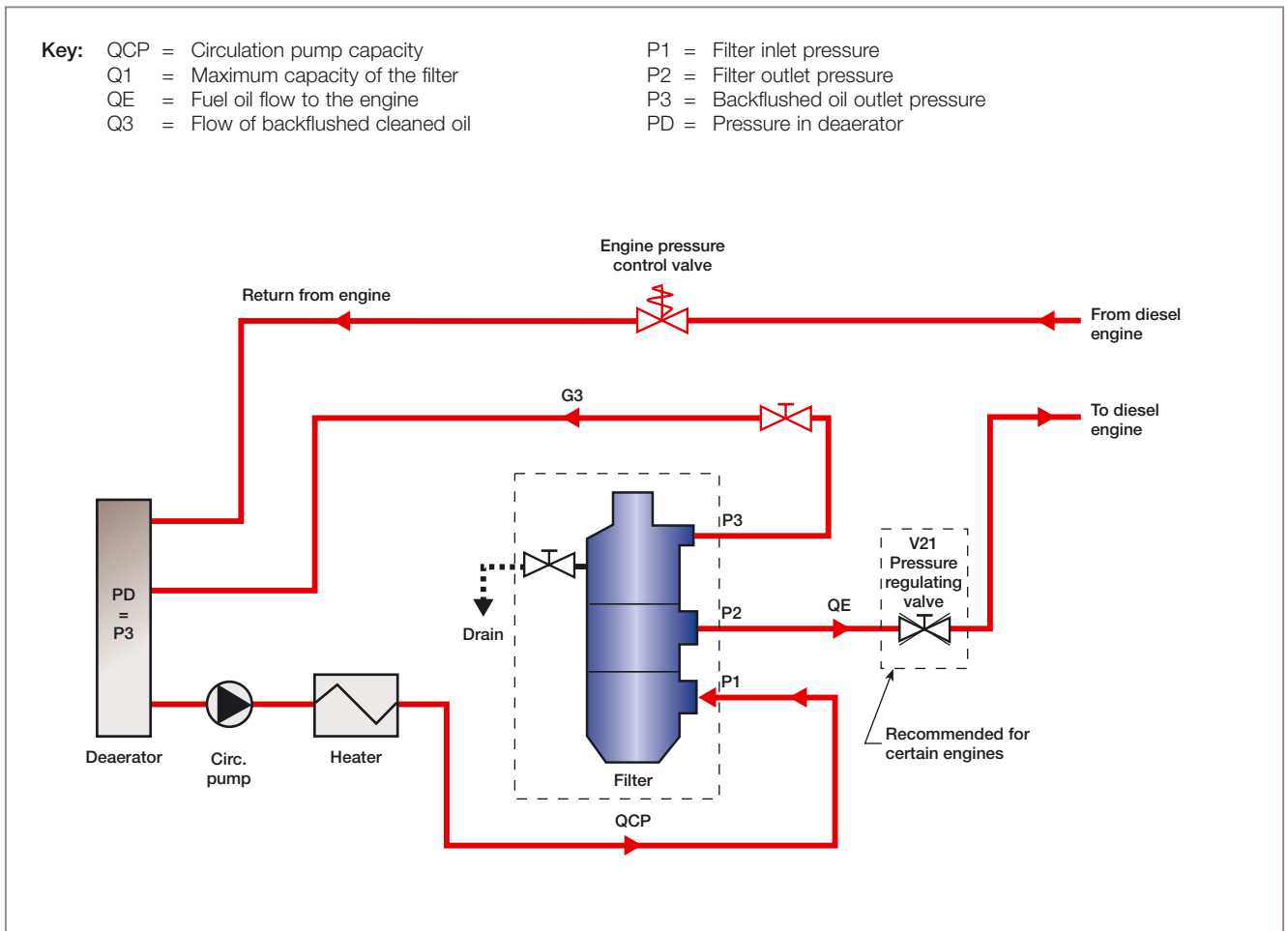

Figure 4. Protective automatic fuel oil filter, shown on the hot side (circulation side) of the booster module.

Operating principle

The unfiltered oil is fed into the filter by means of the distributor, which is driven by an electric motor on top of the filter housing. The distributor rotates on a regular basis, filling seven of the eight full-flow filtering columns. Solids collect on the filter surface and the filtered oil flows to the engine.

In the eighth column, the solids, which have been collected, are removed by backflushing a small amount of the filtered oil through a passage in the distributor to the diversion chamber. This means that all of the columns are backflushed once every time the distributor fully rotates, which occurs approximately every one to two minutes.

The backflushed oil, which contains the solids, enters the diversion chamber and is filtered through seven of its eight columns before being directed back to the deaerator. At the same time, backflushing by clean oil takes place in the eighth column and solids settle to the bottom of the diversion chamber, where they are periodically discharged through the drain cock.

The pressure drop indicator is connected between the inlet and outlet of the full-flow chamber. It provides a reading and signals an alarm if, for any reason, the pressure drop reaches a dangerous level.

The driving force for automatic backflushing is the difference in pressure between the clean-oil outlet (P2) and the backflushed oil outlet (P3) of the filter. A flow sheet illustrating the pressures, flow and capacity is shown in Figure 4. A pressure drop indicator, drain cock and counter flanges are provided as ancillary equipment. Options are available for additional features, such as a drain valve with an automatic timer. The Alfa Laval fuel oil filter is also available with a built-in changeover valve and a built-in bypass filter (see Figure 5), which enable operations to continue uninterrupted during routine maintenance.



Figure 5. Duplex automatic/manual fuel oil filter.

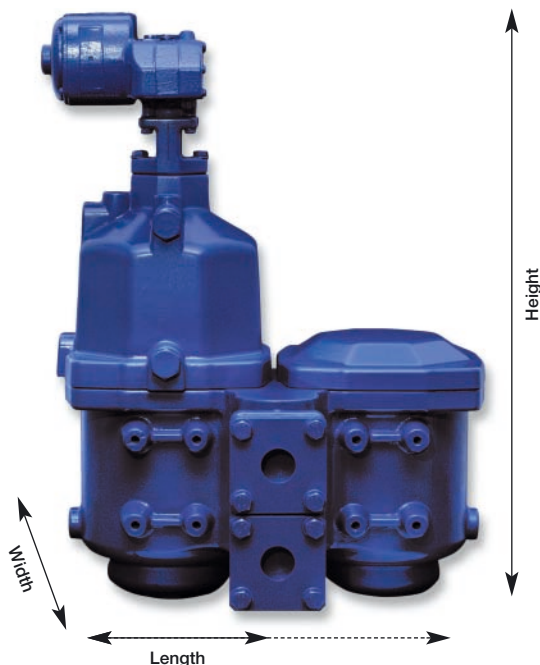

Guidelines to overall dimensions

For flow rates up to 20 m³/h:
 Height x Length x Width (mm): 900 x 250 x 250
 or with the built on bypass: 900 x 660 x 250

For flow rates from 20 to 40 m³/h:
 Height x Length x Width (mm): 1620 x 500 x 450
 or with the built on bypass: 1620 x 1130 x 450

Filtration fineness

From 10 to 45 µm absolute (corresponding to 6 to 30 µm nominal). This can be defined according to diesel engine requirements and the specific application.

Installation

All Alfa Laval automatic fuel oil filters are designed for installation in the engine room. Flanges are according to DIN standards (JIS as option).

Other Alfa Laval filtration products

Alfa Laval also manufactures filters for other engine room applications, such as automatic filters both with and without diversion chamber for lubricating oils, and manual indicator and bypass filters.

After-sales support

Replacement components and after-sales service are provided through a network of Alfa Laval subsidiaries and representatives worldwide, including Marine Service Centres in all major ports.

Technical data

Data	Value
Filter outlet pressure (P2)	
– Min.	2 bar above pressure (P3)
– Recommended	3–5 bar above pressure (P3)
Test pressure	30 bar
Max. viscosity in the filter at normal operation (hot side)	75 cSt
Max. temperature in the filter	160°C
Alarm Δp (P1–P2)	0.8 bar
Housing material	Nodular cast iron
Filter screen material	Stainless steel
Heating method	Steam/hot water/thermal oil
Supply	110/220 V, 50/60 Hz, single phase
Consumption	0.20 A (110 V), 0.10 A (220 V)
Protection	Class F, IP55, tropicalised

Technical documentation

Complete information and documentation for the main components and the installation, operation and maintenance of the filter is contained in the Instruction Book that accompanies delivery of each Alfa Laval filter. Your local Alfa Laval company will be able to provide more details on the application and sizing of Alfa Laval automatic filters.

EMD00046EN 0709

Alfa Laval reserves the right to change specifications without prior notification.

How to contact Alfa Laval

Up-to-date Alfa Laval contact details for all countries are always available on our website at www.alfalaval.com