



# For some, the Perfect Life is Natural Fruit Juices

## FrontLine™ - Widestream® Plate Heat Exchangers

### Application

Pasteurisation and general cooling/heating of fruit juices and other liquid food products which contain pulp or fibres.

### Working principle

A plate heat exchanger consists of a pack of corrugated metal plates with port holes for the passage of two fluids between which heat transfer will take place.

The plate pack is assembled between a fixed frame plate and a movable pressure plate and compressed by tightening bolts.

The plates are fitted with a gasket which seals the inter-plate channel and directs the fluids into alternate channels. The number of plates is determined by the flow rate, physical properties of the fluids and the temperature program.

Connections may be located in frame plate and pressure plate and if multi section PHE, also in connection plate.

### Frame

The plates and the pressure plate are suspended from an upper carrying bar and located by a lower guiding bar, both of which are fixed to the support column. The tightening bolts are equipped with ball bearing washers in order to facilitate opening and closing of the unit. The frame and support column have adjustable feet.

One unit may contain several heat exchangers, separated by connection plates with interchangeable connections.

### The WideStream® plate

The WideStream® plate has a special pattern with few contact points, which allows products containing pulp & fibres to pass without blocking the passages. This results in long operational times without interruptions. The ports have a diameter enabling cleaning in place (CIP) with the same flow used in the process itself. The minimum of contact points between the WideStream® plates results in easy cleaning with short cleaning cycles. The plate pattern is designed for efficient backflushing with free reverse flow.

The WideStream® plate can be used together with other plates in the same heat exchanger frame.

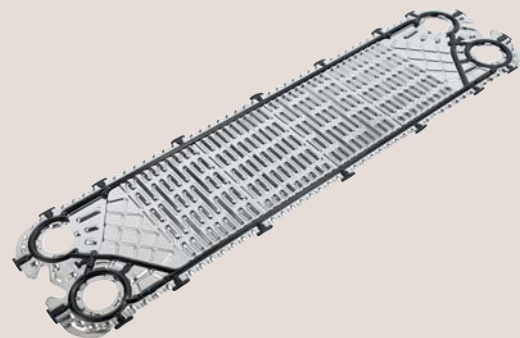

WideStream® plate

## The plate pack

The corrugation of the plates provides a passage between the plates and supports each plate against the adjacent one. It also enhances the turbulence, resulting in efficient heat transfer.

The Alfa Laval hanging system enables easy handling of the plates in the frame. Furthermore the corner guiding provides a strong plate pack. The plates are reversible and have parallel flow, which means that only one type of gasket is needed.

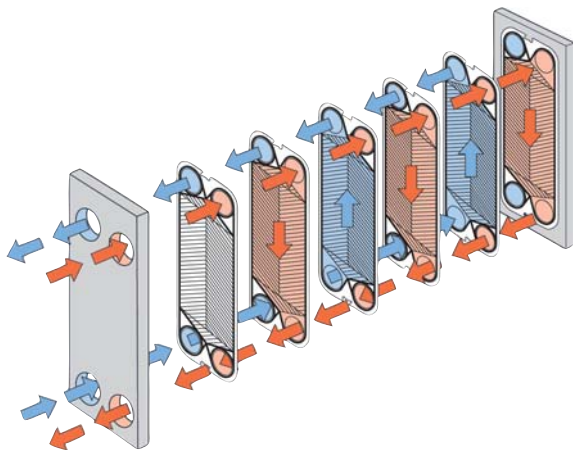

Flow principle of a plate heat exchanger

## Plate Types

Front6 WideStream®, Front8 WideStream®.

Other plates of the FrontLine series are the Front and Gemini plates.

## The gasket

The FrontLine™ plates are supplied with glue-free Clip-On gaskets, which are easy to replace even with the plates still hanging in the frame. The materials of the gaskets are selected for safe use in connection with food products.

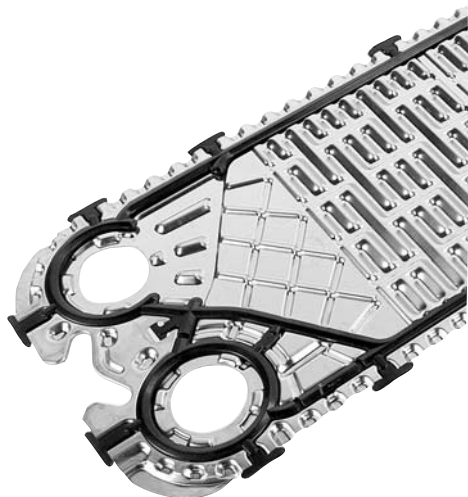

WideStream® plate

## Standard Materials

### Plates

Stainless steel AISI 316 - thickness 0.7 mm

Titanium - thickness 0.9 mm

### Gaskets

High Temperature Nitrile-FDA. Clip-On design.

### Frame

Frame and pressure plate in solid stainless steel. All wetted parts in acid proof stainless steel. Other surfaces in various grades of stainless steel. Movable nuts on tightening bolts in chromium plated brass.

## Technical Data

### Mechanical design pressure (g) / Temperature

FRM – 7 bar / 150 °C

Complies with European Pressure Equipment Directive (PED), may carry the CE mark depending on the design conditions.

### Connections

DIN, SMS, Tri-CLAMP, B.S./RJT and IDF/ISO male parts. Others on request

### Plates

Plates	Front 6 WideStream®	Front 8 WideStream®
Plate pattern	parallel	parallel
Surface m <sup>2</sup>	0.18	0.38
Overall dim., mm	1,000 x 250	1,250 x 375
Port dim., mm	55	80
Thickness, mm	0.7/0.9	0.7/0.9

## Options

- A. Thermometer pocket and nib with ventilation cock<sup>1)</sup>
- B. Thermometer pocket<sup>1)</sup>
- C. Connection for 51 mm pressure transmitter<sup>1)</sup>
- D. Protection sheet
- E. Bolt protections of stainless steel
- F. 3-A finish
- G. Connections in titanium or SMO (frame and pressure plate)
- H. Extended legs
- I. Extra standard wrench or pneumatic tightening tool
- J. Test certificates and material certificate
- K. Testing by authorized inspection companies

All options are not available on all models.

<sup>1)</sup> At through pass corners in connection plates.

**Dimensions (mm)**

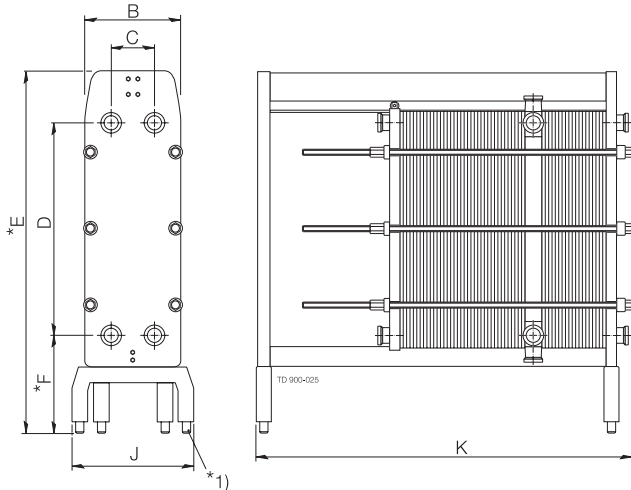

1) Adjustable feet ± 50 mm

Measurements	Front 6 WideStream®	Front 8 WideStream®
B	370	500
C	129	220
D	859	1,095
E	1,420*	1,850*
F	400*	500*
J	520	670
K	1,000-2,500	1,400-3,800

Overall length varies depending on numbers of plates and connecting plates. Recommended free space around the unit is 1.5 meter at sides and frame head end.

Connection	Front 6 WideStream®	Front 8 WideStream®
Diameter mm	51	76

Max. capacity l/h velocity max. 2.0 m/s	Front 6 WideStream®	Front 8 WideStream®
Orange juice - 10 brix		
Pasteurization	7,000	25,000
Heating 2° to 20°C	20,000	32,500
Cooling 25° to 2°C	15,000	32,500