



Hygienic Double Wall Plates Increase Production Safety

FrontLine™ - Gemini Plate Heat Exchangers

Application

Pasteurization and general cooling/heating of dairy, brewery, beverage and food products, when a mixproof design is required. Also applicable for cooling/heating in the pharmaceutical industry.

Working principle

A plate heat exchanger consists of a pack of corrugated metal plates with port holes for the passage of two fluids between which heat transfer will take place.

The plate pack is assembled between a fixed frame plate and a movable pressure plate and compressed by tightening bolts.

The plates are fitted with a gasket which seals the inter-plate channel and directs the fluids into alternate channels. The number of plates is determined by the flow rate, physical properties of the fluids and the temperature program.

Connections may be located in frame plate and pressure plate and if multi section PHE, also in connection plate

Frame

The plates and the pressure plate are suspended from an upper carrying bar and located by a lower guiding bar, both of which are fixed to the support column. The tightening bolts are equipped with ball bearing washers in order to facilitate opening and closing of the unit. The frame and support column have adjustable feet.

One unit may contain several heat exchangers, separated by connection plates with interchangeable connections.

The Gemini plate

The Gemini plates consist of two sheets formed together in order to minimize the inter-sheet air gap reducing the heat transfer.

The gap between the two sheets is in direct contact with the atmosphere and is not in contact with any of the liquids. In order not to trap any liquid between the two sheets, contact to the atmosphere is safeguarded around the whole periphery of the plate.

The Gemini double wall plates will increase the production safety, as a crack in a plate do not result in mixing of the two media.

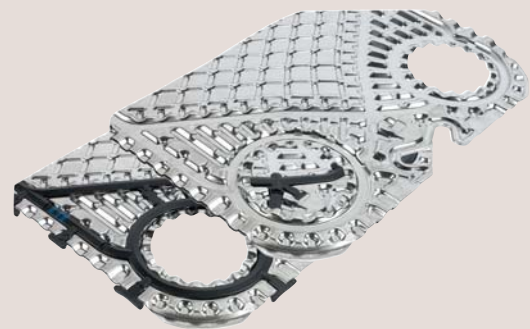

Gemini plate

The plate pack

The chevron corrugation of the plates provides a passage between the plates and supports each plate against the adjacent one. It also enhances the turbulence, resulting in efficient heat transfer.

Different chevron angles are available to reach the optimal high heat transfer at a given pressure drop. A unique distribution area provides an efficient flow over the plate surface. The Alfa Laval hanging system enables easy handling of the plates in the frame. Furthermore the corner guiding provides a strong plate pack. The plates are reversible and have parallel flow, which means that only one type of gasket is needed.

Plate Types

Front6 Gemini, Front8 Gemini and Front10 Gemini.

Other plates of the FrontLine™ series are the Front and WideStream® plates.

The gasket

The FrontLine™ plates are supplied with glue-free Clip-On gaskets, which are easy to replace even with the plates still hanging in the frame. The material of gaskets are selected for safe use in connection with pharmaceutical and food products.

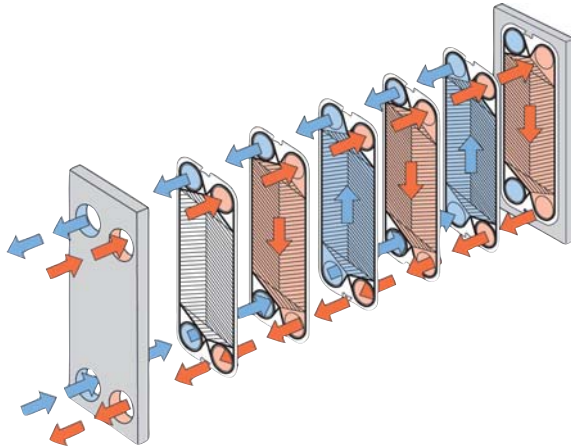

Flow principle of a plate heat exchanger

Standard Materials

Plates

Stainless steel AISI 316

Thickness for all Front Gemini plates 2 x 0.4 mm

Gaskets

High Temperature Nitrile-FDA or EPDM-FDA. Clip-On design.

Frame

Frame and pressure plate in solid stainless steel. All wetted parts in acid proof stainless steel. Other surfaces in various grades of stainless steel. Movable nuts on tightening bolts in chromium plated brass.

Technical Data

Mechanical design pressure (g) / Temperature

FRM – 10 bar / 150 °C

Complies with European Pressure Equipment Directive (PED), may carry the CE mark depending on the design conditions.

Connections

DIN, SMS, Tri-CLAMP, B.S./RJT and IDF/ISO male parts. Others on request

Plates

Plates	Front 6 Gemini	Front 8 Gemini	Front 10 Gemini
Plate pattern	Chevron	Chevron	Chevron
Surface m ²	0.18	0.38	0.62
Overall dim., mm	1,000 x 250	1,250 x 375	1,500 x 500
Port dim., mm	55	80	105
Thickness, mm	2 X 0.4	2 X 0.4	2 X 0.4

Optional

- A. Thermometer pocket and nib with ventilation cock¹⁾
- B. Thermometer pocket¹⁾
- C. Connection for 51 mm pressure transmitter¹⁾
- D. Protection sheet
- E. Bolt protections of stainless steel
- F. 3-A finish
- G. Connections in titanium or SMO (frame and pressure plate)
- H. Extended legs
- I. Extra standard wrench or pneumatic tightening tool
- J. Test certificates and material certificate
- K. Testing by authorized inspection companies

All options are not available on all models.

¹⁾ At through pass corners in connection plates.

Inspection and external indication guarantee

- Sheets have to be split open regularly in order to inspect for cracks not indicated externally.
- Media will not be mixed if a crack appears in one of the sheets.
- External indications of leakage have to be monitored by regular inspections.
- Cracked plates must be replaced as soon as possible:
 - Product between sheets possible source for re-infection and corrosion.
 - Second sheet may also be cracked or corroded.
- Humidity and dust may be sucked in between the sheets:
 - Risk of contamination.
 - Difficult to split sheets.

Single plate sheet in port means use of standard gasket.

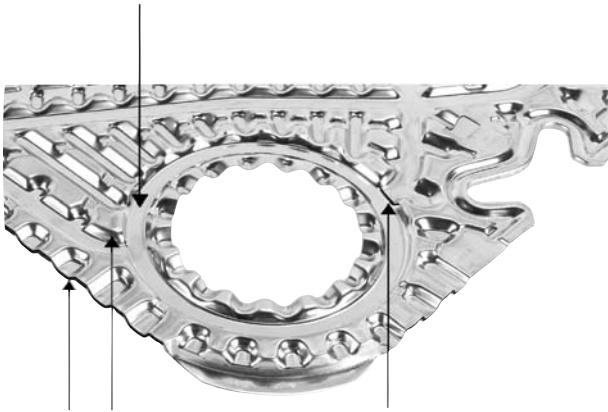

Gap open to atmosphere and not covered by any gasket

Double wall concept

Although the Gemini plates are designed to give an external indication in case of crack in one of the sheets, it may not be the case in some applications. External indications depends on product composition and viscosity, temperature and pressure. If a plate is indicating a crack it must be replaced as soon as possible.

Reduced heat transfer coefficient due to air gap will result in more plates needed.

In order to limit the total number of plates the heat recovery may be reduced.

Dimensions (mm)

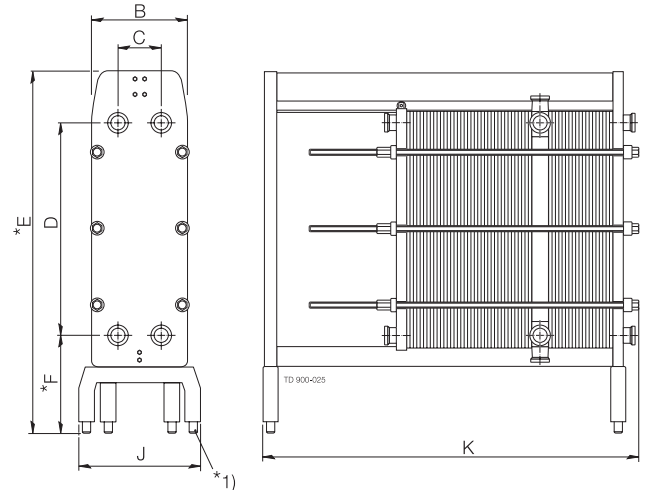

Adjustable feet ± 50 mm

Measurements	Front 6	Front 8	Front 10
B	370	500	670
C	129	220	324
D	859	1,095	1,324
E	1,420*	1,850*	2,167*
F	400*	500*	500*
J	520	670	850
K	1,000-2,500	1,400-3,800	1,400-5,000

Connection	Front 6	Front 8	Front 10
Diameter mm	51	76	76/101.6

Capacity l/h	Front 6	Front 8	Front 10
Pasteurization	8,000	20,000	50,000
Heating/Cooling	15,000	35,000	65,000
Water	30,000	75,000	130,000

Overall length varies depending on numbers of plates and connecting plates. Recommended free space around the unit is 1.5 meter at sides and frame head end.