



Foodec 800

Food-focused decanter centrifuge



Foodec 800 decanter centrifuge

Application

Alfa Laval Foodec decanter centrifuges are designed for food and beverage applications where good hygiene practices are essential in order to comply with strict sanitary regulations. These decanter centrifuges are available for both 2-phase and 3-phase separation. They are ideal for use in the food industry in situations where the material being processed has to be separated into either a liquid and a solids phase, or into two liquid phases and a solids phase.

Standard design

Alfa Laval designed the Foodec decanter centrifuge with a focus on hygiene, reliability, easy access and low noise levels. The rotating assembly is mounted on a compact welded box beam frame with main bearings at both ends. The cover is hinged to enable easy access for inspection, cleaning and maintenance. The in-line motor is mounted on the decanter with adjustable brackets to make it easy to adjust belt tension. The bowl is driven at the inlet end by an electric motor and V-belt transmission.

The bowl, conveyor, casing, inlet tube, outlets and all other parts in contact with the process media are made of AISI 316 stainless steel and duplex stainless steel.

Operating principles

Separation takes place in a horizontal cylindrical bowl equipped with a screw conveyor. The product is fed into the bowl through a stationary inlet tube and is smoothly accelerated by an inlet rotor. Centrifugal forces cause instant sedimentation of the solids on the wall of the bowl. The conveyor rotates in the same direction as the bowl, but at a different speed, thus moving the solids towards the conical end of the bowl.

The new Foodec design enables the hydraulic pressure inside the bowl to improve scrolling through a narrow opening. Only the driest fraction of the solids leaves the bowl through the solids discharge openings into the casing. Separation takes place throughout the total length of the cylindrical part of the bowl, and the clarified liquid leaves the bowl by flowing over adjustable plate dams into the casing.

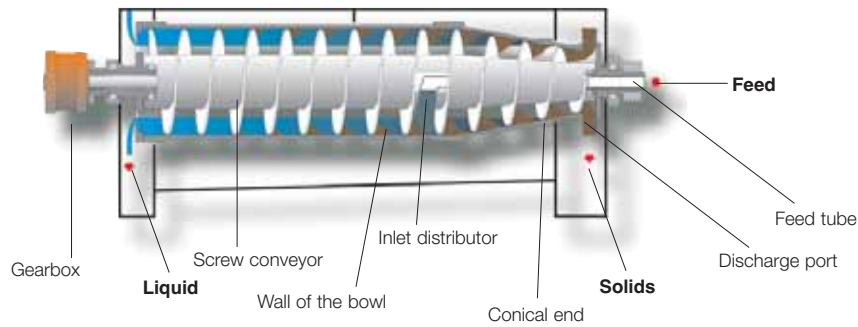

Process optimization

Foodec decenter centrifuges can be adjusted to suit individual requirements by varying

- bowl speed to achieve the required G-force for the best possible separation
- conveyor differential speed to ensure the ideal balance between liquid clarity and solids dryness
- pond depth in the bowl for the right balance between liquid clarity and solids dryness
- feed flow according to individual requirements.

Direct Drive

Direct Drive is a unique system developed by Alfa Laval for automatic control of the differential speed between the bowl and the conveyor. This makes it easy to maintain the best possible balance between liquid clarity and solids dryness irrespective of variations in the feed.

Direct Drive comprises a new type of gearbox and variable frequency drive, which does not expose the bowl drive to

parasitic braking power loss. The electrical installation is straightforward, power consumption is kept to a minimum, and accurate control is achieved within a wide range of differentials with no need to change belts and pulleys.

Decanter Core Controller (DCC)

Foodec decenter centrifuges are operated via a dedicated control system with a central processor that features a graphic interface. The DCC monitors and adjusts the direct drive to match the solids load in the bowl.

A number of other parameters are also monitored to ensure easy, safe, reliable operations and optimized process performance.

Customers can also integrate Foodec decenter centrifuges into their existing system using external bus options available from several major manufacturers.



Foodec 800 with bar for CIP



Screen for Decanter Core Controller (DCC)

Options

Foodec decanter centrifuges provide design options such as grooves in the bowl to provide a more hygienic way to transport the material being processed through the unit. Other options include a paring disc and a complet purge system to keep foaming to a minimum and limit oxidation; pulp wash facilities; process rinse and a full cleaning-in-place (CIP) capability, as well as FDA-approved elastomers and seals.

ATEX-compliant decanters are available for zone 1, 2 and 22.



Grooves in the decanter bowl

Dimensions

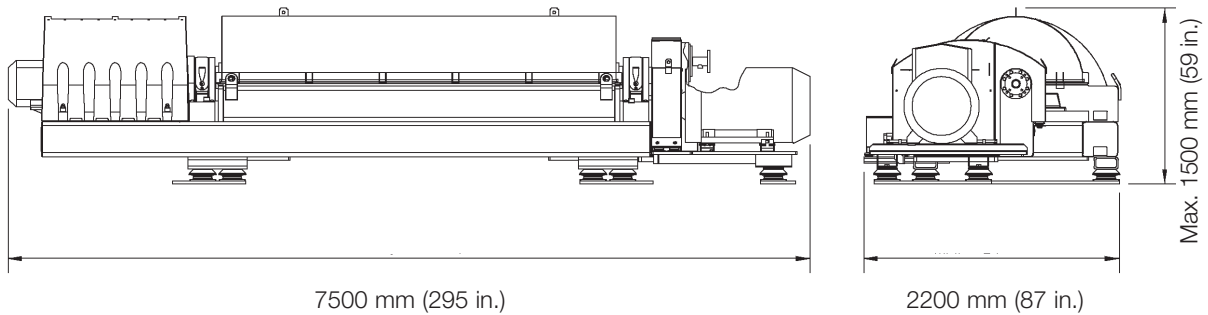

Technical data

		Foodec 800
Capacity		Depends on application
G-force max.		3243
Bowl material		Duplex stainless steel
Other wetted parts		AISI 316
Weight	kg.	13000 (28860 lbs)
Installed Power	kW	132 – 250 (140 – 330 Hp)
Sound pressure level ¹	dB(A) re. 20µPa	89

¹ Declared A-weighted emission sound pressure level in free field over a reflecting plane at 1 m distance from the decanter, operating at maximum bowl speed, tested with water and closed outlet.