



Cetetherm Maxi C1

District Heating Substation

The Cetetherm Maxi C1 is a high-quality and standardised district heating substation by Alfa Laval. It features ready-made basic although configurable solutions for all heating and domestic hot water requirements.

Applications

The Maxi C1 District Heating Substation is appropriate for a wide range of uses from single small multi-family houses to blocks of multi-family houses as well as both new and renovated buildings. Maxi C1 is always built to dimensions appropriate to the site.

General features

Maxi C1 is a district heating substation based on limited component selection by Alfa Laval. Due to its standard component solutions, the delivery time is short. The dimensions of property doors have been taken into account in the construction of the unit, making it easy to move the Maxi C1 indoors and connect it to the building's heating system.

Dimension

In constructing the substation, the Alfa System Select calculation software is utilised. The selection of components is defined by, for instance, capacity, temperatures and the maximum pressure drops.

Components

All components and pipes are measured and selected according to the dimensions and requests from the designers and authorities. Alfa Laval uses only well-known components tested by themselves in its products. Most pipes and brass parts are developed by AL. Maxi C1 can be equipped with either a constant-curve or intelligent speed controlled E-pump for the heating side. Maxi C1 includes a Combibox solution which contains the control centre and pump switches in the same well protected (IP54) cabin. GSM modem accessory for remote control and the ability to read by SMS message can



be added (dependant upon the control centre). Temperature measurements can be obtained from the control centre or by using normal thermometers.

Brazed heat exchangers

In Maxi C1 District Heating Substations, brazed plate heat exchangers are BHE, incorporated as standard. The BHE is made of acid-proof steel and is brazed with pure copper. Considering its size, the BHE is quite powerful, since practically all the material used within functions as a heat exchange surface. Due to the threaded and flanged coupling employed, the heat exchangers are always easy to detach.

The heat exchangers are insulated with 30 mm environmentally-friendly, Freon-free polyurethane which can be easily opened, and are coated with hard ABS plastic.

Main components

1. Heat exchanger (domestic hot water)
2. Heat exchanger (heating)
3. Combibox including control centre and pump switches
4. Control valve, heating
5. Pump, heating
6. Control valve, domestic hot water
7. Pump, domestic hot water circulation

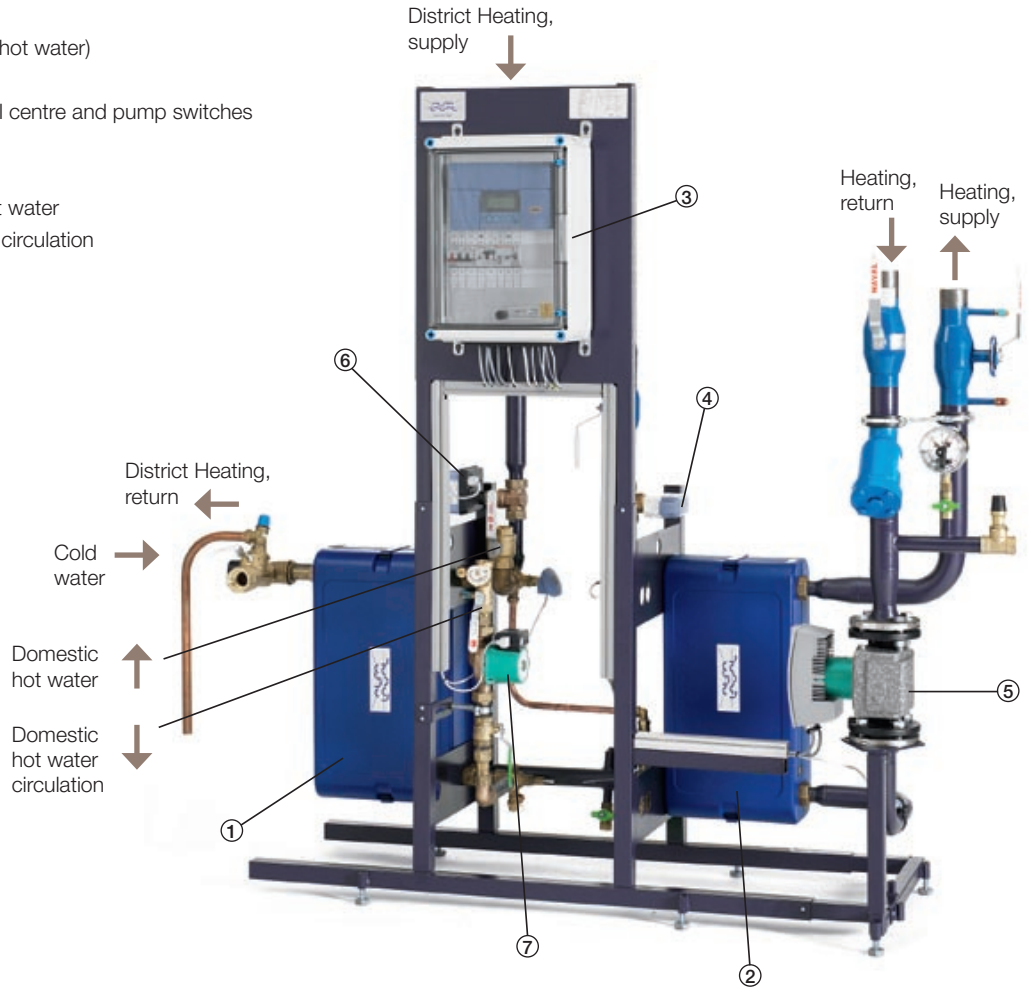

Typical flow chart for Cetetherm Maxi C1. Components can vary due to individual calculations.

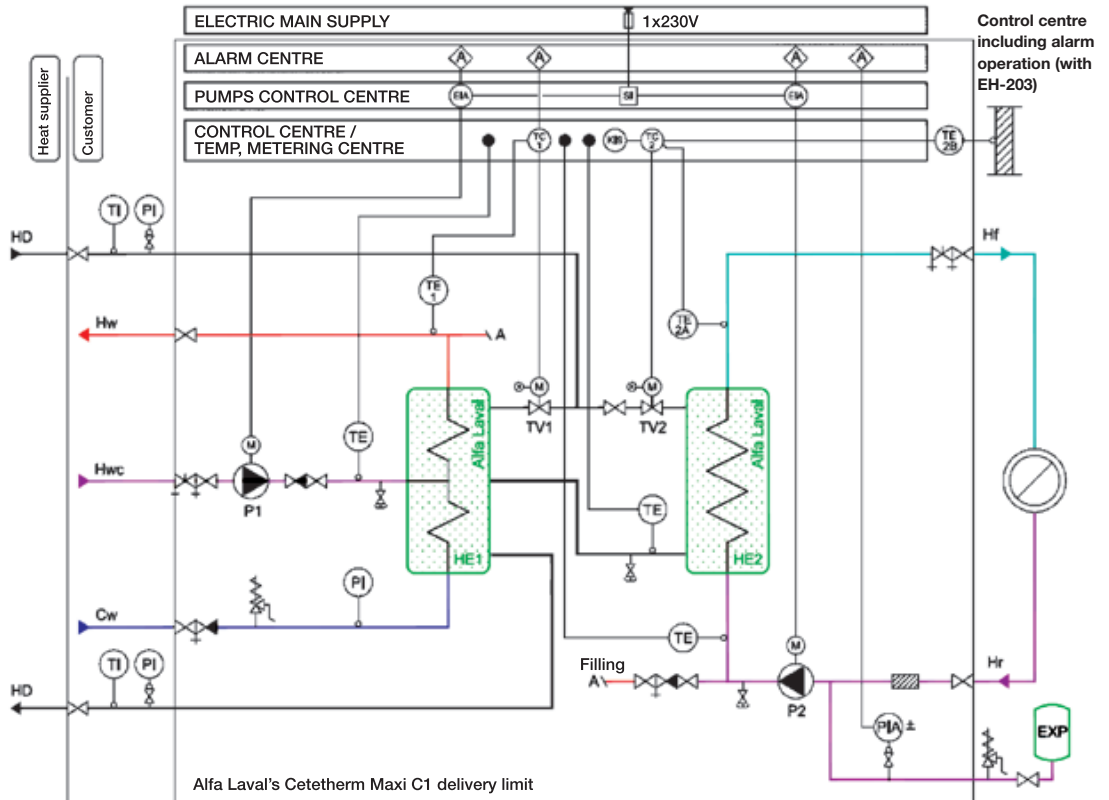

Operating data

	District heating	Domestic hot water	Heating
Design pressure	16 bar	10 bar	6 bar
Design temperature	120 C	100 C	100 C

Approvals and reliability

Alfa Laval's quality system observes the ISO 9001 standard. All products are manufactured in accordance with CE and PED requirements. Maxi C1 fulfils all local and national authority requirements.

Dimensions of Cetetherm Maxi C1 with typical capacities

Power (kW)		Substation dimensions			
Domestic water	Heating	Length (mm)	Width (mm)	Height (mm)	Weight (kg)
200	100	1500	660	1550	100
350	200	1650	660	1550	150
400	300	1650	660	1600	170
500	500	1750	700	1650	230

Benefits

- With clear frame solutions it is possible to assemble the unit close to the wall. Service and maintenance work is also easy to carry out with all components situated at the front of substation.
- Modularised component and piping solutions aid installation, and options are easy to add.
- Strong and stable frame ensures unbreakable transportation and extended lifetime for the unit.
- Clear positions for primary and secondary sides.
- Due to the narrow construction the unit is easy to transfer to the technical room.



All documents, e.g. instructions, are placed in a box located behind the electrical panel.



Adjustable feet aid installation.

Alfa System Select – calculation tool for dimension work.

For the design of the Cetetherm Maxi C1 unit Alfa Laval offers advanced calculation software. Some of the features can be found at Alfa System Select:

- easy and fast to use
- several languages are available for displays and printouts
- internet updating
- multiple printouts; technical specification, flow chart, measurement details etc.

To get this free software please contact Alfa Laval sales.