



Brazed heat exchangers

A product catalogue for refrigeration



The brazed plate heat exchanger (BHE) is a well-established component in a refrigeration plant. In refrigeration plants where Alfa Laval BHEs are installed, typical equipment includes:

- **Chiller:** Cools water or brine and rejects the heat to air or water. The water is transported by a hydraulic system through different types of heat exchanger to cool air in an air conditioning system or to cool manufacturing or industrial processes. Two basic systems are normally used to drive chillers: a compressor driven by an electric motor, based on a vapour compression refrigeration cycle; or a heat-driven system (steam, burning natural gas), based on an absorption refrigeration cycle.
- **Heat pump:** A type of water chiller that can also run in a reverse cycle, also called a water-source heat pump. In this case the primary function is heating water and rejecting the cool to air or water. The heated water warms up air in the air conditioning system. Another variation of this system is

ground source heat pumps, using the earth or water surface to add or reject the heat.

The BHE is an efficient solution for a range of functions in the refrigeration plant. The most common of these involve transferring heat from two basic media: the refrigerant as the primary fluid (HFC or natural gas) and water or brines as the secondary fluid:

- Evaporator, dry expansion, cooling water,
- Condenser, rejecting or recovering heat to water,
- Desuperheater for partial heat recovery to water,
- Economizer, cooling liquid refrigerant and superheating vapour refrigerant.

Other possible functions:

- Subcooler to cool down the liquid refrigerant using well water,
- Intermediate heat exchangers used in the absorption cycle to preheat the diluted solution or to pre-cool the concentrated solution.



Air conditioning



Commercial refrigeration



Industrial refrigeration

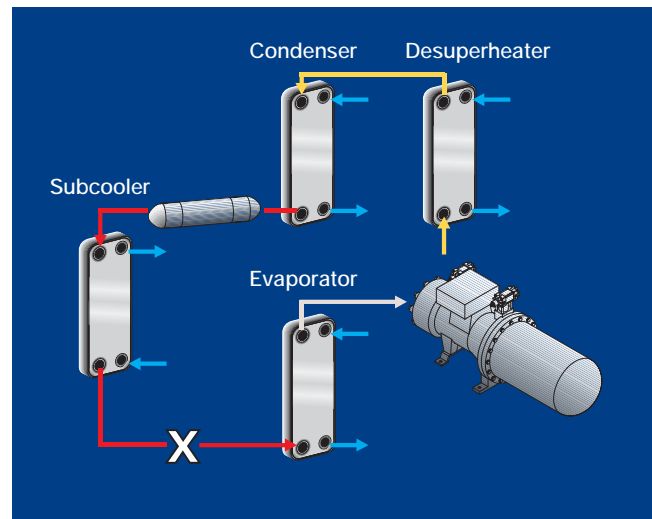

Chiller component scheme



- 1 Extensive range of BHE models providing wide range of cooling capacities from 0.5 to 600 kW.
- 2 Patented innovations, the Equalancer and Dualaced systems, give high heat transfer performance.
- 3 Equalancer system provides a heat transfer surface saving of -20% compared to BHE with traditional distribution system.
- 4 -40% m³/kW space saving due to the compact design of BHE compared to Shell and Tube heat exchangers.
- 5 +7% water chiller COP due to high BHE performance compared to traditional heat exchangers.
- 6 Rapid response to changes in temperature due to small hold-up volume and lower refrigerant charge.
- 7 Optimized design for every duty with customized BHE configuration to customer's own specifications.
- 8 All widely recognized pressure vessel codes available as standard.
- 9 Every BHE is pressure and leak tested before delivery, ensuring top quality products.

The Alfa Laval brazed heat exchanger

Developed in the late seventies, the Alfa Laval BHE is the original brazed plate heat exchanger. The BHE concept is a variation on the traditional plate and frame heat exchanger, but without gaskets and frame parts.

- Compact and durable
- Easy to install
- Cost efficient



Design

Brazing the stainless steel plates together eliminates the need for sealing gaskets and thick frame plates. As well as holding the plates together at the contact points, the brazing material seals the package. Alfa Laval's brazed heat exchangers are brazed at all contact points, ensuring optimal heat transfer efficiency and pressure resistance. The plates are designed to achieve longest possible lifetimes.

Since virtually all material is used for heat transfer, the BHE is very compact in size and has a low weight and a low hold-up volume. Alfa Laval offers a flexible design that can be customized to meet customer-specific requirements. Alfa Laval brazed plate heat exchangers ensure the customer the most cost-efficient solution for his heat transfer duties.

Material

The brazed plate heat exchanger (BHE) consists of thin corrugated stainless steel plates which are vacuum brazed together using copper as the brazing material. Copper brazed units can be used for numerous of applications. However, for food applications and applications involving aggressive fluids, copper brazed units are not suitable. For those applications, the optimal solution is an AlfaNova Fusion Plate Heat Exchanger made of 100% stainless steel.

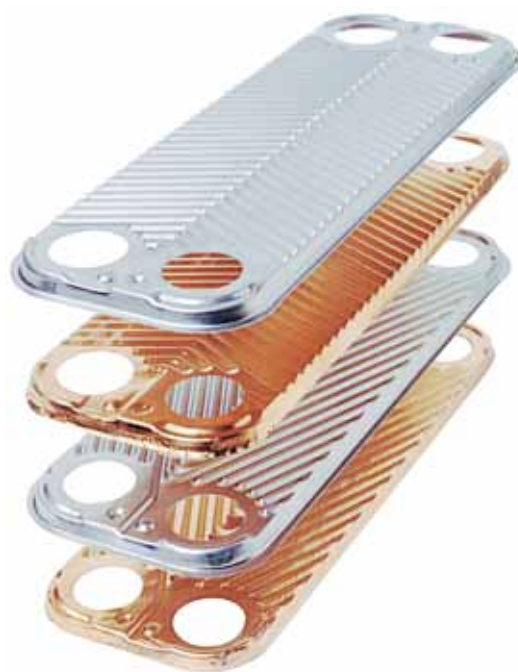



- First class manufacturing facilities
- High and consistent quality
- Leak and pressure testing of all units before delivery

Flow principle

The basic flow principle in a brazed heat exchanger for HVAC applications is parallel and current flow to achieve the most efficient heat transfer process. In a single pass design all connections are located on one side of the heat exchanger, making installation very easy.

Evaporator flow principle

The channels formed between the corrugated plates and corners are arranged so that the two media flow through alternate channels, always in opposite directions (counter current flow). The two phase refrigerant (vapour + liquid) enters the bottom left of the exchanger with a vapour quality depending on the operating condition of the plant. Evaporation of the liquid phase takes place inside the channels and some degrees of superheat are always requested, which is the reason why the process is called "dry expansion". In the enclosed evap-

orator picture the dark and light blue arrows show the location of the refrigerant connections. The water (brine) to be cooled flows counter current in the opposite channel; the dark and light red arrows show the location of the water (brine) connections.

Brazed plate condensers – flow principle

The main components are the same as for the evaporator. The refrigerant enters at top left of the exchanger as hot gas and starts to condense on the surface of the channels until fully condensed, and is then slightly subcooled. The process is called "free condensation". In the enclosed condenser picture the light and dark blue arrows show the location of the brine connections. The refrigerant flows counter current in the opposite channel and is cooled. The light and dark red arrows indicate the locations of the refrigerant connections.

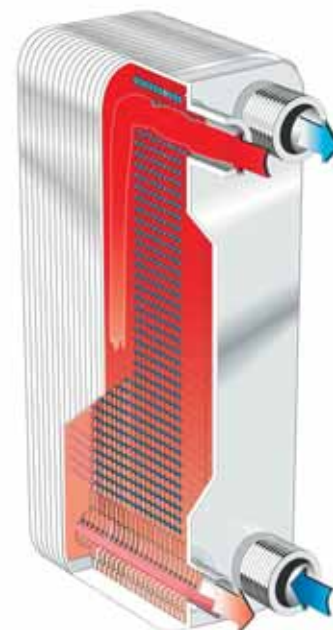

Equalancer system

Alfa Laval Research & Development has developed innovative solutions for the refrigerant fluid distribution inside a BHE. These have been laboratory tested using HCFC and HFC refrigerants with excellent results.

The two phase flow coming into the evaporators is mixed by the patented distribution systems "X" or "EQ" which stabilizes the flow and increases performance.

The performance of the evaporators in the AlfaChill series (AC30, 50, 80, 120, 130, 250 and 350) has been continuously improved. Using the patented Equalancer system it is pos-

sible to obtain a double mixing of refrigerant into two successive volumes. This ensures a more balanced distribution system through all the plate channels which reduces fluctuations in the superheating effect.

Pressed into the plate, the Equalancer system guarantees high quality and repeatability of plate design and performance.

The Equalancer system does not have an adverse effect on the BHE operating as condenser since the pressure drop is negligible.



Dualaced system

The real dual circuit patented by Alfa Laval in a solution with diagonal flow is obtained by means of pressed plates. The BHE can be connected with two independent refrigerant circuits. The special design ensures that each refrigerant circuit is in contact with the entire water flow. The main advantage is

that at partial load (only one compressor running) water cooling is uniform and performance is maximized. Alfa Laval has implemented the Dualaced real dual circuit (DQ) in the AC80, 130, 250 and 350 BHE models.

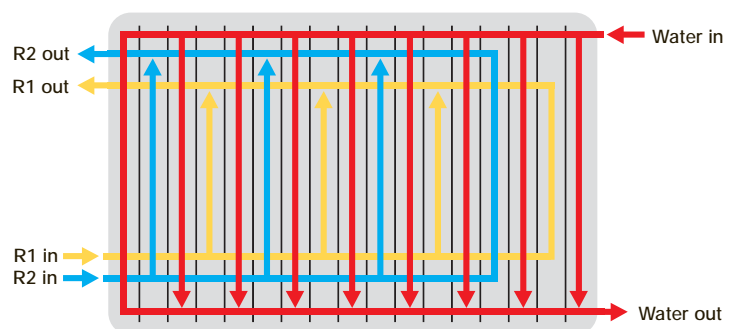

Multipass

The design options of the brazed heat exchanger are extensive. The heat exchanger can be designed as a multipass unit, different types of connections are available, and there is the option of choosing the location of the connections. Alfa Laval offers a wide range of standard heat exchanger models and sizes, tailor-made for HVAC applications and available from stock. Naturally, customer-specific designs are available on request.

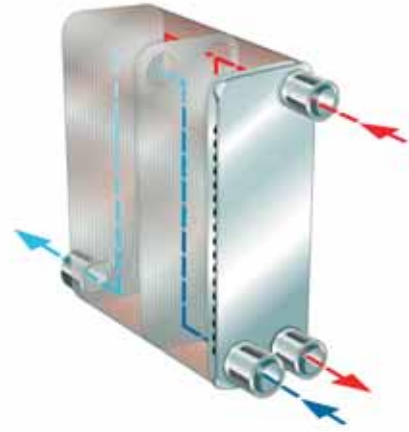

Production

Alfa Laval is leading the trend towards optimal quality. We do it with advanced production technology in high volumes. We do it with new technology through constant research and development. We do it through deliveries and service. As a leading global manufacturer we do it by offering a complete range of heat exchangers. Our knowledge gives you the best

solutions, products with higher technical performance and a focus on energy savings. Quality must prevail through the whole chain from development to after-sales. All our brazed heat exchangers are individually leak and pressure tested to ensure first-class quality, and Alfa Laval has approvals from all major approval bodies.



Stacking machine



Brazing oven



Testing machine

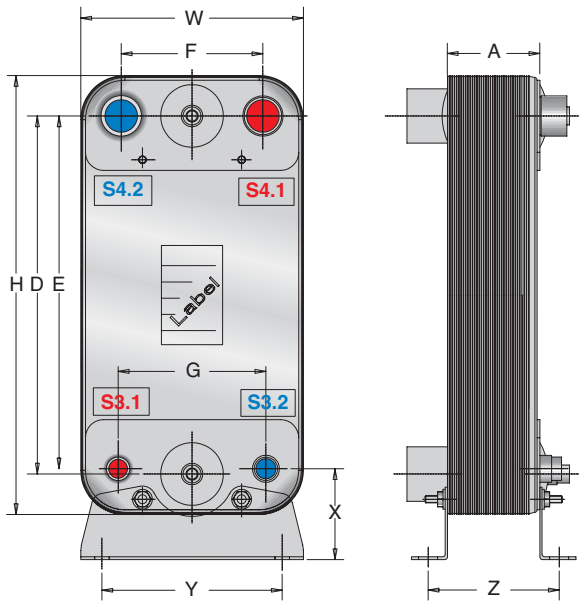

BHE Data & Dimensions	AC10	CB26/27
Cooling capacity range CC [kW]	1-4	(*)
Channel type	H	L, M, H
Distribution system type	-	-
Double refrigerant circuits "Dualacer"	-	-
Standard design pressure S3-S4/S1-S2 side [barg]	32/32	32/32
Standard min/max design temp. [°C]	-160/175	-160/175
High design pressure S3-S4/S1-S2 side [barg]	-	49/49
Channel volume, S3-S4/S1-S2 side [l]	0.02/0.02	0.05/0.05
Maximum number of plates	50	150
Height, H [mm]	208	310
Width, W [mm]	77	111
Vertical connection distance, E, D [mm]	172	250
Horizontal connection distance, F, G [mm]	42	50
Plate pack length, A [mm]	8+(2.35*NP)	9+(2.4*NP)
Weight, empty [kg]	0.7+(0.06*NP)	1.2+(0.13*NP)

(*) recommended for applications with low refrigerant pressure drop as desuperheater and oil cooler • NP = number of plates • Design pressure and temperature could have different values depending on the notified body.

Support feet	AC10	CB26/27
Height, X (mm)	-	-
Width, Y (mm)	-	-
Length, Z (mm)	-	-
Support feet material	-	-

Standard connections

AC10	POSITION	NAME	SIZE	TYPE
Ref IN	S3	G21	ODS 18 mm	Internal soldering
Ref OUT	S4			
Water side	S1-S2, T1-T2	A21	3/4"	Ext. threaded (ISO 228/1-G)

CB26/27	STD POSITION	NAME	SIZE	TYPE
Ref IN	S3	H21	ODS 1"1/8	Internal soldering
	S3	R21	1"1/4 - 12UNF	Rotalock
Ref OUT	S4	H21	ODS 1"1/8	Internal soldering
	S4	R21	1"1/4 - 12UNF	Rotalock
Water side	S1-S2, T1-T2	B21	1"	Ext. threaded (ISO 228/1-G)

AC30	STD POSITION	NAME	SIZE	TYPE
Ref IN	S3	H27-H62	ODS 3/8" - 1/2"	Internal soldering
		H65, H66, H67	ODS 5/8"	
Ref OUT	S4	H23-H21	ODS 7/8" - 1"1/8	Ext. threaded (ISO 228/1-G)
Water side	S1-S2, T1-T2	B21	1" BSP	

CB52	STD POSITION	NAME	SIZE	TYPE
Ref IN	S3	H21	ODS 1"1/8	Internal soldering
	S3	R21	1"1/4 - 12UNF	Rotalock
Ref OUT	S4	H21	ODS 1"1/8	Internal soldering
	S4	R21	1"1/4 - 12UNF	Rotalock
Water side	S1-S2, T1-T2	B21	1"	Ext. threaded (ISO 228/1-G)

AC50	STD POSITION	NAME	SIZE	TYPE
Ref IN	S3	H24	ODS 1/2"	Internal soldering
		H51-H52	ODS 5/8"	Internal soldering
		H60-H61	ODS 7/8"	Internal soldering
Ref OUT	S4	H21	ODS 1"1/8	Internal soldering
		H34	ODS 1"3/8	Internal soldering
Water side	S1-S2, T1-T2	B21	1"	Ext. threaded (ISO 228/1-G)
	S1-S2, T1-T2	B32	1"1/4	Ext. threaded (ISO 228/1-G)

CB76	POSITION	NAME	SIZE	TYPE
Ref IN	S3	D21	ODS 2"1/8	Internal soldering
Ref OUT	S4			
Water side	S1-S2, T1-T2	B23	2"	Ext. threaded (ISO 228/1-G)

AC30	CB52	AC50	CB76	AC80	AC120	AC130	AC250-DQ	AC350
5-30	10-30	10-55	(*)	40-80	50-200	50-200	150-450	300-600
EQ	L, M, H	HX	H,L,M	EQ	EQ	DQ	EQ/DQ	EQ/DQ
Equalancer	-	X	-	Equalancer	Equalancer	Equalancer	Equalancer	Equalancer
-	-	-	-	Dualacer	-	Dualacer	Dualacer	Dualacer
32/32	32/32	32/30	32/32	32/25	32/30	34/25	32/32	32/32
-50/150	-160/175	-50/150	-160/175	-50/150	-50/150	-50/150	-50/150	-160/150
45/45		45/32			45/45			
0.028/0.028	0.095/0.095	0.095/0.095	0.25/0.25	0.08/0.08	0.21	0.16	0.45/0.4	0.45/0.4
120	150	150	190	118	200	230	270	270
325	526	526	618	390	617	487	741	741
93	111	111	191	195	192	247	324	324
269	466	466	519	296	519	391/397	599/628	599/628
39/40	50	50	92	120.8/119.6	92	157.2/163.7	211/232	211/232
9+(1.5*NP)	10+(2.4*NP)	10+(2.4*NP)	10+(2.85*NP)	12+(1.96*NP)	11+(2.35*NP)	8+(2.2*NP)	13.5+(2.82*NP)	13.5+(2.82*NP)
1+(0.09*NP)	1.8+(0.23*NP)	1.8+(0.23*NP)	7+(0.44*NP)	3.45+(0.24*NP)	7.6+(0.44*NP)	6.5+(0.38*NP)	13+(0.82*NP)	13+(0.84*NP)

AC30	CB52	AC50	CB76	AC80	AC120	AC130	AC250	AC350	
-	-	-	199	-	199	101	135	135	
-	-	-	208	-	208	200	290	290	
-	-	-	A+120	-	A+120	A+42	A+54	A+54	
-	-	-	Carbon steel galvanized						

AC80DQ	POSITION	NAME	SIZE	TYPE
Ref IN	S3	H22, H51, H52, D57	ODS 5/8"	Internal soldering
	S3	H56, H58, H30	ODS 7/8"	
Ref OUT	S4	D27	ODS 1*1/8	
	S4	D26	ODS 1*3/8	
Water side	S1-S2, T1-T2	C31	1/2"	Int. threaded (ISO 228/1-G)
	S1-S2, T1-T2	B33	1*1/2	Ext. threaded (ISO 228/1-G)

AC120EQ	POSITION	NAME	SIZE	TYPE
Ref IN	S3	H56, H57	ODS 7/8"	Internal soldering
	S3	L54, L55, L56	ODS 1*1/8	
Ref OUT	S4	D21	ODS 2*1/8	
Water side	S1-S2 T1-T2	B23	2" BSP	Ext. threaded (pipe thread ISO 228/1)

AC130DQ	POSITION	NAME	SIZE	TYPE
Ref IN	S3	H23, H58, H59	ODS 7/8"	Internal soldering
	S3	H21, L54, L55, L56, L58	ODS 1*1/8	
Ref OUT	S4	H25	ODS 1*5/8	
	S4	D21	ODS 2*1/8	
Water side	S1-S2, T1-T2	C31	1/2" FBSP	Int. threaded (ISO 228/1-G)
	S1-S2, T1-T2	P32	2"	For flexible joint type (Victaulic)
	S1-S2, T1-T2	P31	2*1/2	

AC250EQ/DQ	POSITION	NAME	SIZE	TYPE
Ref IN	S3	D55, D54	ODS 1*1/8	For soldering
	S3	M51, 52, 53, 54, 55, 56, 57	ODS 1*3/8	
Ref OUT	S4	L33	ODS 2*5/8	
	S4	L35	ODS 3*1/8	
Water side	S1-S2, T1-T2	C31	1/2"	Inside threaded (pipe thread ISO 228/1-G)
	S1-S2, T1-T2	P35	3"	For flexible joint type (Victaulic)

AC350	POSITION	NAME	SIZE	TYPE
Ref IN	S3	D55, D54	ODS 1*1/8	For soldering
	S3	M51, 52, 53, 54, 55, 56, 57	ODS 1*3/8	
Ref OUT	S4	L33	ODS 2*5/8	
	S4	L35	ODS 3*1/8	
Water side	S1-S2, T1-T2	L33	1/2"	Inside threaded (pipe thread ISO 228/1-G)
	S1-S2, T1-T2	L35	3"	For flexible joint type (Victaulic)

CB26/27 Evaporator						
	R407C Tdew = 4.5°C H2O 12/7°C		R404a Tdew = -10°C 30% eth gly 0/-5°C		R404a Tdew = -15°C 35% eth gly -5/-10°C	
N. of plates	kW	Δp (kPa)	kW	Δp (kPa)	kW	Δp (kPa)
10	2,0	3,0				
20	4,3	3,0				
30	6,0	3,0				
34	6,5	2,7				
40	7,2	2,5				
50	8,3	2,3				

AC30 Evaporator						
	R407C Tdew = 5°C H2O 12/7°C		R404a Tdew = -10°C 30% eth gly 0/-5°C		R404a Tdew = -15°C 35% eth gly -5/-10°C	
N. of plates	kW	Δp (kPa)	kW	Δp (kPa)	kW	Δp (kPa)
20	6,1	37	5,0	40	4,7	40
30	9,0	36	7,5	40	7,0	40
36	10,9	37	9,0	40	8,4	40
44	13,4	37	10,9	40	10,2	40
54	16,5	38	13,3	40	12,4	40
60	18,2	38	14,8	40	13,7	40
70	20,7	37	17,1	40	15,7	39
80	22,6	35	19,0	39	17,7	39
100	25,2	30	23,3	39	21,0	37

AC50 Evaporator						
	R407C Tdew = 4.5°C H2O 12/7°C		R404a Tdew = -10°C 30% eth gly 0/-5°C		R404a Tdew = -15°C 35% eth gly -5/-10°C	
N. of plates	kW	Δp (kPa)	kW	Δp (kPa)	kW	Δp (kPa)
10	5,6	33	3,8	23	3,1	18
20	12,5	45	8,4	27	6,9	22
30	19,4	45	13,1	29	10,7	24
40	25,5	44	17,2	29	14,0	23
50	31,0	42	20,9	28	17,1	23
60	36,0	40	24,3	27	19,8	22
80	46,0	39	31,1	26	25,3	21
100	52,5	34	35,4	23	28,9	18
120	55,0	30	37,1	19	30,3	15

AC80 Evaporator						
	R407C Tdew = 4.5°C H2O 12/7°C		R404a Tdew = -10°C 30% eth gly 0/-5°C		R404a Tdew = -15°C 35% eth gly -5/-10°C	
N. of plates	kW	Δp (kPa)	kW	Δp (kPa)	kW	Δp (kPa)
42	31	23	20	15	16	15
50	38	24	25	15,5	20	15
58	44	25	29	16	23	15
66	50	26	32	16	26	15
74	56	26	36	16	29	15
86	63	26	41	16	33	15
102	72	26	47	16	38	15
118	80	26	52	16	42	15

AC120EQ Evaporator						
	R407C Tdew = 4.5°C H2O 12/7°C		R404a Tdew = -10°C 30% eth gly 0/-5°C		R404a Tdew = -15°C 35% eth gly -5/-10°C	
N. of plates	kW	Δp (kPa)	kW	Δp (kPa)	kW	Δp (kPa)
40	54	39	36	26	28	17
50	68	40	45	26	35	18
60	82	41	54	26	42	18
70	95	41	63	26	49	18
90	119	40	78	25	61	17
110	141	40	93	25	72	17
130	159	38	104	24	81	16
150	173	37	114	23	89	15

AC130DQ Evaporator						
	R407C Tdew = 4.5°C H2O 12/7°C		R404a Tdew = -10°C 30% eth gly 0/-5°C		R404a Tdew = -15°C 35% eth gly -5/-10°C	
N. of plates	kW	Δp (kPa)	kW	Δp (kPa)	kW	Δp (kPa)
82	99	36,0	55	18	42	17
102	123	37,0	68	19	52	18
122	146	38,0	80	20	62	17
142	167	38,0	92	19	71	16
162	187	39,0	103	19	80	16
182	204	39,0	112	19	88	16
202	218	38,4	120	18	93	15

AC250EQ / AC250DQ Evaporator						
	R407C Tdew = 4.5°C H2O 12/7°C		R404a Tdew = -10°C 30% eth gly 0/-5°C		R404a Tdew = -15°C 35% eth gly -5/-10°C	
N. of plates	kW	Δp (kPa)	kW	Δp (kPa)	kW	Δp (kPa)
60	134	32	102	26	79,5	19
80	179	32	136	27	106,1	20
100	221	33	168	26	131,1	20
120	260	32	198	26	154,2	19
140	293	32	223	25	173,7	19
160	322	31	245	24	190,9	18
180	344	29	261	24	203,0	17
200	359	27	273	22	212,9	16

AC350DQ Evaporator						
	R407C Tdew = 4.5°C H2O 12/7°C		R404a Tdew = -10°C 30% eth gly 0/-5°C		R404a Tdew = -15°C 35% eth gly -5/-10°C	
N. of plates	kW	Δp (kPa)	kW	Δp (kPa)	kW	Δp (kPa)
110	315	55	218	38	170	27
130	392	64	276	44	214	31
150	445	65	316	45	247	32
170	495	65	354	47	276	33
190	528	64	380	45	295	32
210	545	59	395	43	308	30

Notes: Evaporator performances are referred to counter current flow, superheating 5K

	Multiplier factor kW
R134a Tdew 2°C	0.9 x R407C
R22 Tdew 2°C	1 x R407C

AC10 Condenser						
	R407C Tdew = 52.5°C H2O 40/45°C		R134a Tdew = 50°C H2O 40/45°C		R404a Tc = 50°C H2O 40/45°C	
N. of plates	kW	Δp (kPa)	kW	Δp (kPa)	kW	Δp (kPa)
10	1,2	1,0	1,0	0,9	1,2	1,0
14	1,6	1,0	1,4	1,0	1,6	1,0
20	2,3	1,1	2,0	1,0	2,3	1,1
28	3,2	1,2	2,8	1,2	3,2	1,2

CB26/27H Condenser						
	R407C Tdew = 52.5°C H2O 40/45°C		R134a Tdew = 50°C H2O 40/45°C		R404a Tc = 50°C H2O 40/45°C	
N. of plates	kW	Δp (kPa)	kW	Δp (kPa)	kW	Δp (kPa)
10	2,2	3,2	1,9	2,1	2,2	3,2
14	3,5	4,0	2,8	2,5	3,5	4,0
20	5,2	4,5	4,2	3,0	5,2	4,5
24	6,3	4,6	5,1	3,0	6,3	4,6
30	7,9	4,8	6,5	3,3	7,9	4,8
34	9,0	4,8	7,3	3,3	9,0	4,8
40	10,5	4,9	8,5	3,3	10,5	4,9
50	13,3	5,3	10,9	3,6	13,3	5,3

AC30 Condenser						
	R407C Tdew = 51°C H2O 45/40°C		R134a Tdew = 49°C H2O 45/40°C		R404a Tc = 49°C H2O 45/40°C	
N. of plates	kW	Δp (kPa)	kW	Δp (kPa)	kW	Δp (kPa)
20	6,5	37	6,5	37	6,5	37
24	7,8	37	7,8	37	7,8	37
30	9,7	37	9,7	37	9,7	37
36	11,6	37	11,7	37	11,7	37
44	14,3	38	14,4	38	14,4	38
54	17,4	38	17,4	38	17,4	38
60	19,5	39	19,5	39	19,5	39
70	22,9	40	22,9	40	22,9	40
80	26,3	42	26,3	42	26,3	42
100	33,0	44	33,0	44	33,0	44

AC50 Condenser						
	R407C Tdew = 51°C H2O 45/40°C		R134a Tdew = 49°C H2O 40/45°C		R404a Tc = 49°C H2O 40/45°C	
N. of plates	kW	Δp (kPa)	kW	Δp (kPa)	kW	Δp (kPa)
10	7,0	45	6,0	37	7,0	45
14	9,8	46	8,3	37	9,8	46
20	14,0	47	11,9	37	14,0	47
30	21,0	47	17,9	38	21,0	47
34	23,8	47	20,2	38	23,8	47
40	28,0	47	23,8	38	28,0	47
50	35,0	48	29,8	39	35,0	48
60	42,0	48	35,7	40	42,0	48
80	56,0	51	47,6	43	56,0	51
100	70,0	55	59,5	44	70,0	55
120	84,0	58	71,4	47	84,0	58

AC120EQ Condenser						
N. of plates	R407C Tdew = 52.5°C H2O 40/45°C		R134a Tdew = 50°C H2O 40/45°C		R404a Tc = 50°C H2O 40/45°C	
	kW	Δp (kPa)	kW	Δp (kPa)	kW	Δp (kPa)
40	52	34	44	25	52	34
50	65	35	55	25	65	35
60	78	35	66	26	78	35
70	91	36	77	26	91	36
90	117	37	99	27	117	37
110	143	39	122	29	143	39
130	169	41	144	30	169	41
150	195	44	166	32	195	44

AC250EQ Condenser						
N. of plates	R407C Tdew = 52.5°C H2O 40/45°C		R134a Tdew = 50°C H2O 40/45°C		R404a Tc = 50°C H2O 40/45°C	
	kW	Δp (kPa)	kW	Δp (kPa)	kW	Δp (kPa)
60	144	37	122	27	144	37
70	168	38	143	27	168	38
80	192	38	163	27	192	38
90	216	39	184	28	216	39
100	240	39	204	28	240	39
120	288	41	245	29	288	41
140	336	42	286	31	336	42
160	384	44	326	32	384	44
180	432	47	367	34	432	47
200	480	50	408	36	480	50

AC350EQ Condenser						
N. of plates	R407C Tdew = 52.5°C H2O 40/45°C		R134a Tdew = 50°C H2O 40/45°C		R404a Tc = 50°C H2O 40/45°C	
	kW	Δp (kPa)	kW	Δp (kPa)	kW	Δp (kPa)
110	264	40	220	28	280	45
150	360	43	300	30	380	48
190	456	48	375	33	470	51
210	504	51	410	34	515	54
230	552	55	440	35	560	56
250	580	55	470	36	585	56
270	620	57	510	40	630	60

Notes:

Condenser performances are referred to counter current flow with subcooling 2K and FF= 0 [m2K/W]

Same performances with water 30/35°C and Tdew=42.5°C or Tdew=40°C

Co-current flow need a higher Tdew +2K to get same performances, Tdew 52.5 -> Tdew 54.5, Tdew 50 -> Tdew 52°C

Cleaning-In-Place (CIP)

All types of heat exchangers need to be cleaned regularly to remove deposits such as scale, sludge and microorganisms. Alfa-CIP is a convenient solution that carefully removes the deposit on all heat transfer surfaces in the heat exchanger. Alfa-CIP 75, 200 and 400 are constructed in stainless steel using high quality components (pumps, valves etc.) according to ISO 9001 and with the CE-mark. The smaller units Alfa-CIP 20 and 40 are made of industrial grade plastic. Alfa-CIP is mobile due to its compact design. The units have reversible flow, and Alfa-CIP 75, 200 and 400 also have a built in heater. All cleaning detergents used by Alfa Laval are environmentally friendly and do not damage the equipment.



KIT water connections

The KIT is for flexible joint connection Vicatolic or Gruvlock type. They are based on two components the clamp with gasket seal and the counter pipe. The seal is in EPDM and therefore must not be used in contact with oil and hydrocarbons in general and outside the temperature range of -40/+80 °C. For these or other special applications, to evaluate which type of seal should be used, contact the Alfa Laval sales department.

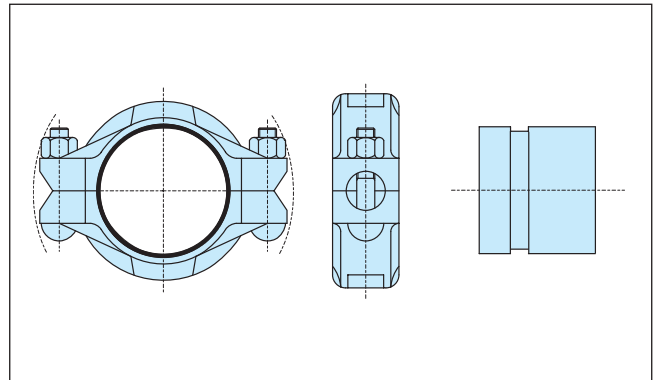

BHE type	To fit conn. type	Pipe size	Type
AC130	P32	2"	Flexible joint KIT
AC130	P31	2" 1/2	Flexible joint KIT
AC250/AC350	P35	3"	Flexible joint KIT

Kit adaptor sensors and blinding plugs

These extra connections are normally used with 6 connections BHE, material is stainless steel AISI 316L. The adaptor KIT is mainly used to fit in the water temperature relief sensors for the chiller control devices. Blinding plugs are common tap to close connections are not used.

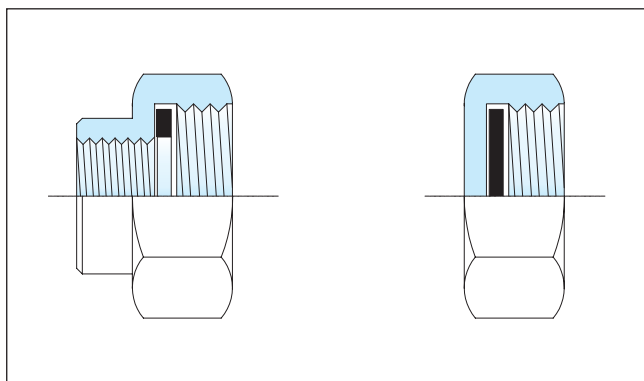

BHE type	To fit conn. type	Adaptor size	Type
AC30 CB26/27H CB52 AC50	B21	from 1" to 1/2"	Internal threaded (ISO 228/1-G)
AC50	B32	from 1"1/4 to 1/2"	Internal threaded (ISO 228/1-G)
CB76 AC120 AC130	B23	from 2" to 1/2"	Internal threaded (ISO 228/1-G)

Feet and mounting brackets

CB26/27 and larger units can be delivered with feet or mounting brackets. These make the installation work easier and minimise stresses in the connected pipes. The unit can also be bolted to the floor. AC30, CB26/27, AC50, AC80, CB76 and AC120 can be wall mounted using the standard feet frame.

AC130, AC250 and AC350 can be supplied with feet and a lifting hook to ensure safe and functional installation.