

ALBIN MG

RUBBER LOBE PUMP

VOLUMETRIC RUBBER LOBE PUMP

APPLICATIONS

The MG pump allows the transfer of viscous and fibrous products, polymers, latex, slurries, sludges, pastes and muds also containing abrasive and suspended solids with a maximum size of 30 mm.

Industrial applications: Lime milk, Molasses, resins, paper, ceramics, tiles industries, in the machining of glass and marble.

Water treatment: Sewage Thickened, Sludge Dewatered, Sludge Clarifier, Waste Activated Sludge, Digested Sludge, Primary Sludge, Lime Milk, Raw Sludge

Petrochemical: Crude oil, Solvents, heavy oils, Cleaning of petroleum sludge food industry, in agriculture, in drilling plants, etc.

OPERATING PRINCIPLE

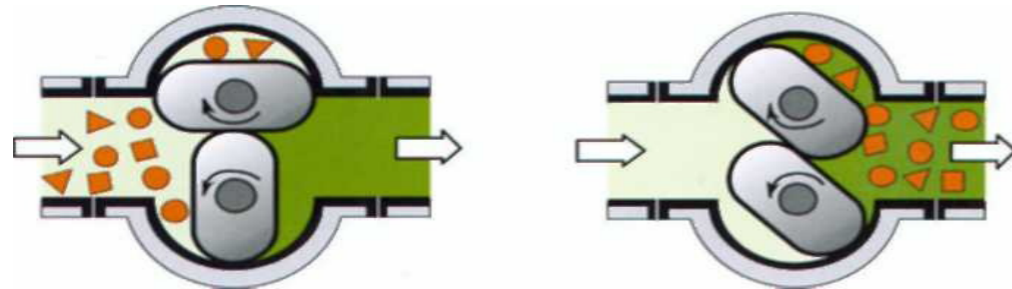

Albin MG Rotary Lobe Pumps are self-priming, valveless, positive displacement pumps. Two synchronized rotors rotating against each other build chambers towards the pump casing. At the suction side the open chambers fill with the conveyed product. The product is displaced in the direction of the volume flow into the discharge side. The capacity is speed related and the flow is reversible. The flow of the média can be reversed simply by changing the direction of the rotation. The rotating lobes are rubber coated; it is consequently possible to pump random solids.

CONSTRUCTION

Designing the MG pump particular care has been dedicated to improve pump life and limit maintenance operations.

Standard version:

- Housing: GG30 cast iron
- Lobes: Cast iron coated with NBR
- Shoulders: Wear resistant steel (400 HB)
- Shaft seals: Double radial seals, grease lubricated
- Sliding on hardened bushes manifolds: Galvanized steel

Special versions are available for specific applications.

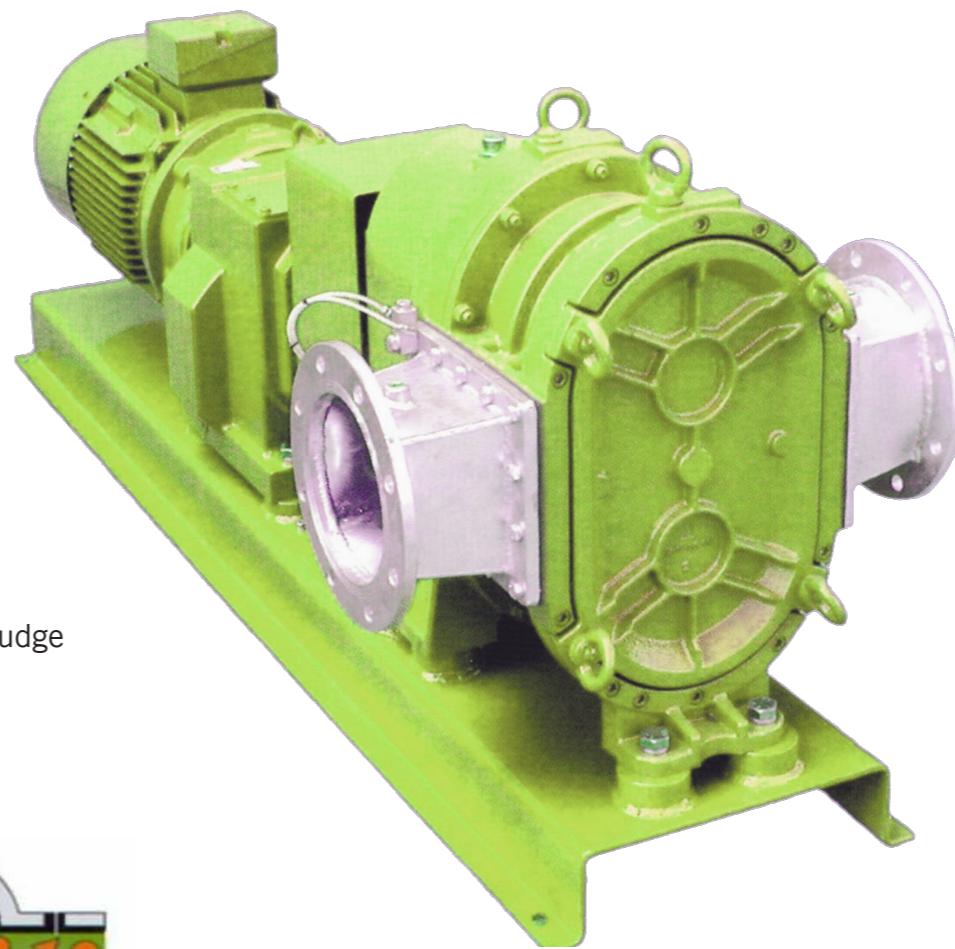
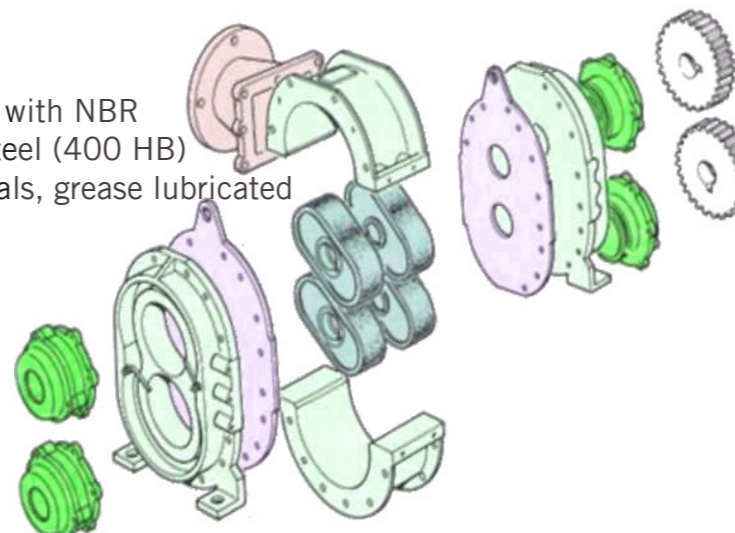

FLOW TABLE

Speed R.p.m	100	225	450	540	750	1000
	Flow rate (M3/h)					
MG 02	1,4	3	6	7	10	13
MG 04	2,6	6	12	14	20	27
MG 07	7,5	17	34	40		
MG 14	14	31	65	78		
MG 20	21	47	95	114		
MG 27	30	67	134	161		
MG 35	40	90	180	216		
MG 40	42	96	192	231		
MG 50	60	130	260	310		

Continuous duties
Intermittent duties
Occasional use

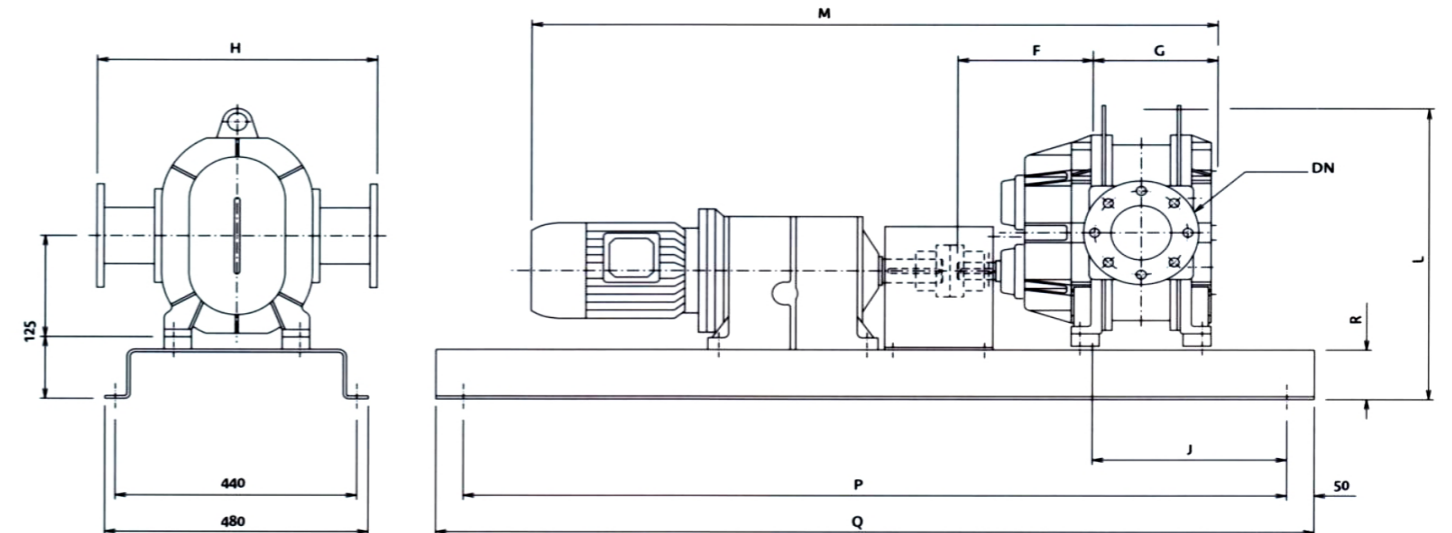
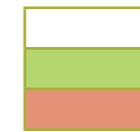

DIMENSIONS - MM

	A	B	C	D	E	F	G	H	I	J	L	R	Connections	Weight Bare pump Kg
MG 02	90	25g6	40	92	M12	256	64	331	134	114	416	50	DN 50	50
MG 04	90	25g6	40	92	M12	273	81	331	134	131	416	50	DN 80	60
MG 07	135	1"3/8	70	135	14	214	296	580	205	229	588	100	DN 80	97
MG 14	135	1"3/8	70	135	14	247	223	510	205	261	588	100	DN100	105
MG 20	135	1"3/8	70	135	14	280	254	610	205	295	608	100	DN150	119
MG 27	135	1"3/8	70	135	14	318	295	610	205	333	646	100	DN150	146
MG 35	215	1"3/4	98	207	22	548	207	671	309	257	725	100	DN175	335
MG 40	135	1"3/8	70	135	14	384	363	840	205	398	546	100	DN175	170
MG 50	215	1"3/4	98	207	22	598	256	671	309	306	725	100	DN200	380



Different motorization are available to suit the customers needs:
Electric (ATEX), Hydraulic for truck mounting, Thermic (portable units)

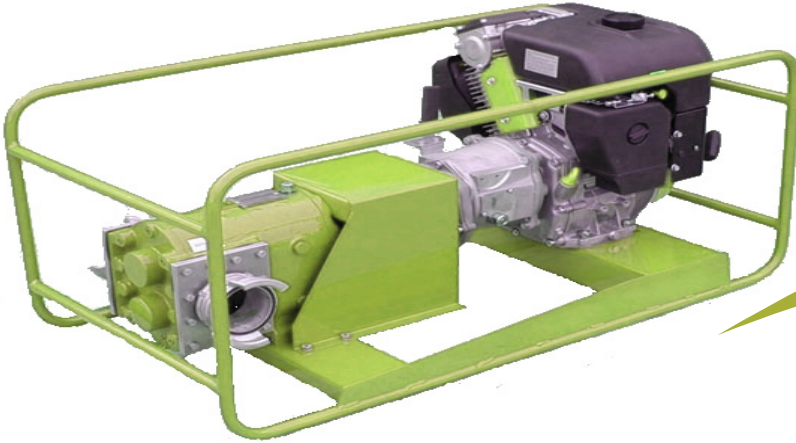

Albin Pump SAS
ZAC de Fontgrave
26740 Montboucher sur Jabron
France
Tel +33 (0) 4 75 90 92 92
Fax +33 (0) 4 75 90 92 40
info@albinpump.fr
www.albinpump.fr

Albin Pump AB (Headoffice)
Ålegårdsgatan 1
S-431 50 Mölndal
Sweden
Tel +46 (0)31 701 38 36
Fax +46 (0)31 22 14 37
info@albinpump.se
www.albinpump.se

Packaging - Processing
Bid on Equipment
1-847-683-7720
www.bid-on-equipment.com