



2 1/2 - 15 Ton Air Over Hydraulic Press

The C-Series Air-Hydraulic Press is a more cost and energy efficient alternative to the Full Hydraulic Press Machine

These C-Series Units come in four sizes ranging from 2.5 ton to 15 ton capacity. Standard features include a full length power stroke, 2.0" adjustable down-stop, and an anti-rotation ram guide. These heavy duty C-frame Units can be mounted on a floor stand or bench top and have an adjustable force and speed control.

What Makes Us Better

As air enters the booster cylinder, oil is displaced in the hydraulic cylinder above. The displaced oil enters the ram cylinder and drives the ram down. Unlike other brands, pressure is maintained throughout the entire stroke. When the valve is de-energized, the ram retracts to its home position.

Advantages:

- Fewer moving parts
- Less maintenance, less down time
- Less noise
- Full length power stroke
- Less heat
- Cost less than electric powered hydraulic presses.



Specifications				
Description	2.5 Ton Press	5.5 Ton Press	10 Ton Press	15 Ton Press
Tons at 100 psi Air	2.5	5.5	10	15
Power Ratio (No. x air line psi = Approx. Force)	50	110	200	300
Max. Ram Stroke (adjustable 2" shorter)	5-3/16"	6"	4"	6"
Cubic in. of Pressurized Air Per Full Stroke Cycle	577	1562	1865	4521
Air Cyl. Port Pipe Size - 4 Way Control Valve	1/2"	3/4"	3/4"	1"
Return Force @ 100 psi	628	1080	1080	2003
Booster Cylinder				
Inside Diameter	6"	8"	8"	12"
Rod Diameter	2-1/8"	2-1/2"	1-7/8"	3-1/4"
Stroke	10-1/4"	15-5/8"	18-1/2"	20-3/16"
Ram Cylinder				
Inside Diameter	3"	4"	4"	5-3/4"
Top Rod Diameter	0.750"	1.000"	1.000"	1.250"
Bottom Rod Diameter	1.000"	1.500"	1.500"	2.750"
Net Weight	350lbs.	500lbs.	500lbs.	800lbs.

Contact Us Today Phone: 1-800-837-4355 or Email: info@airhydraulics.com

air-hydraulics INCORPORATED

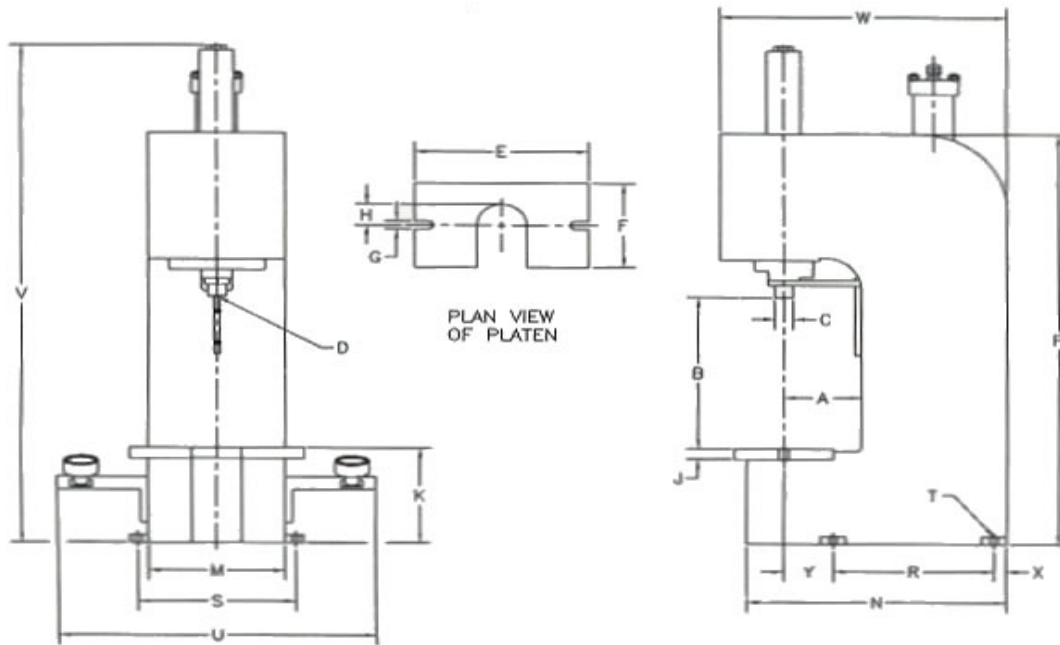

DIM KEY	Description	C-250	C-300	C-400	C-500
A	Throat Depth	6.25	6.25	6.25	8.25
B	Daylight	12.00	14.43	14.43	14.00
C	Ram Diameter	1.000	1.500	1.500	2.750
D	Ram Mounting	5/8-11 x 1.25	5/8-11 x 1.25	5/8-11 x 1.25	1 1/4-12 x 1.88
E	Platen Width	12.50	14.00	14.00	18.00
F	Platen Depth	6.00	8.00	8.00	10.00
G	Platen Slot	0.62 x 1.50	0.75 x 1.50	0.75 x 1.50	1.25 x .88
H	Platen Radius	2.00	2.00	2.00	2.25
J	Platen Thickness	1.00	1.00	1.00	1.25
K	Platen To Floor	7.12	9.00	9.00	9.00
M	Frame Width	9.50	11.00	11.00	15.25
N	Frame Depth	18.00	21.00	21.00	28.00
P	Frame Height	32.12	39.00	39.00	40.00
R	Mounting Hole Depth	10.00	13.00	13.00	16.00
S	Mounting Hole Width	11.25	12.75	12.75	17.00
T	Mounting Hole	0.53	0.62	0.62	0.65
U	Overall Width	23.75*	25.25*	25.25*	29.50*
V	Overall Height	39.50*	46.50*	48.00*	52.00*
W	Overall Depth	20.00*	23.12*	23.12*	29.75*
X	Back Foot Mounting	1.00	1.00	1.00	1.25
Y	Front Foot Mounting	5.00	4.00	4.00	6.75

* Denotes Approximate Dimensions

Contact Us Today Phone: 1-800-837-4355 or Email: info@airhydraulics.com



Standard Features and Options

Model C-250 Air over Oil Press (2.5 Ton)

Standard Features

- 2.5 Tons of Force @ 100 psi of Factory Supplied Air
- No Hydraulic Power Unit or Electric Motor Needed
- Full Length Hydraulic Controlled Power Stroke
- 5-3/16" Overall Stroke with 2.0" Stroke Adjustment
- Anti-Rotation Ram Guide
- Hydraulic Flow Control (Speed Control)
- Heavy Duty Steel Welded C-Frame Construction
- 12.00" Daylight Opening / 6.25" Throat Depth
- Available in Bench Top or Floor Model

Available Options

- Two-Hand Non-Tie Down Control Packages
- Pressure / Dwell / Distance Return Options
- Light Curtain & Guarding Package
- PLC Control Options
- Increased Stroke Lengths
- Custom Design Frames Dimensions
- Available in 4-Post & 2-Post Designs
- Load Cell & Distance Monitoring Packages
- Custom Designed Tooling Package

Model C-300 Air over Oil Press (5.5 Ton)

Standard Features

- 5.5 Tons of Force @ 100 psi of Factory Supplied Air
- No Hydraulic Power Unit or Electric Motor Needed
- Full Length Hydraulic Controlled Power Stroke
- 6.0" Overall Stroke with 2.0" Stroke Adjustment
- Anti-Rotation Ram Guide
- Hydraulic Flow Control (Speed Control)
- Heavy Duty Steel Welded C-Frame Construction
- 14.43" Daylight Opening / 6.25" Throat Depth
- Available in Bench Top or Floor Model

Available Options

- Two-Hand Non-Tie Down Control Packages
- Pressure / Dwell / Distance Return Options
- Light Curtain & Guarding Package
- PLC Control Options
- Increased Stroke Lengths
- Custom Design Frames Dimensions
- Available in 4-Post & 2-Post Designs
- Load Cell & Distance Monitoring Packages
- Custom Designed Tooling Package



Model C-400 Air over Oil Press (10 Ton)

Standard Features

- 10 Tons of Force @ 100 psi of Factory Supplied Air
- No Hydraulic Power Unit or Electric Motor Needed
- Full Length Hydraulic Controlled Power Stroke
- 4.0" Overall Stroke with 2.0" Stroke Adjustment
- Anti-Rotation Ram Guide
- Hydraulic Flow Control (Speed Control)
- Heavy Duty Steel Welded C-Frame Construction
- 14.43" Daylight Opening / 6.25" Throat Depth
- Available in Bench Top or Floor Model

Available Options

- Two-Hand Non-Tie Down Control Packages
- Pressure / Dwell / Distance Return Options
- Light Curtain & Guarding Package
- PLC Control Options
- Increased Stroke Lengths
- Custom Design Frames Dimensions
- Available in 4-Post & 2-Post Designs
- Load Cell & Distance Monitoring Packages
- Custom Designed Tooling Package

Model C-500 Air over Oil Press (15 Ton)

Standard Features

- 15 Tons of Force @ 100 psi of Factory Supplied Air
- No Hydraulic Power Unit or Electric Motor Needed
- Full Length Hydraulic Controlled Power Stroke
- 6.0" Overall Stroke with 2.0" Stroke Adjustment
- Anti-Rotation Ram Guide
- Hydraulic Flow Control (Speed Control)
- Heavy Duty Steel Welded C-Frame Construction
- 14.00" Daylight Opening / 8.25" Throat Depth
- Available in Bench Top or Floor Model

Available Options

- Two-Hand Non-Tie Down Control Packages
- Pressure / Dwell / Distance Return Options
- Light Curtain & Guarding Package
- PLC Control Options
- Increased Stroke Lengths
- Custom Design Frames Dimensions
- Available in 4-Post & 2-Post Designs
- Load Cell & Distance Monitoring Packages
- Custom Designed Tooling Package



C-Series Air-Hydraulic Press Control Packages (standard packages)

DP = Pneumatic

(No Electricity Needed)

DP-1 or EDP-1 Control Package:

Basic two-hand non-tie control package. The operator initiates both actuators at the same time to advance the press stroke. Once the operator releases one of both actuators, the cylinder rod/ram returns to home position (Available Options & Add-on Features: DR, TD, PSRO, 24VDC, PLC, SLC, SS1122, E-LPT, SIG)

DP-2 or EDP-2 Control Package:

Low force approach stroke with adjustable hydraulic intensified boost stroke. This package is beneficial for C-Series Press with additional (non-standard) stroke lengths. The operator initiates both actuators at the same time to advance the press stroke under a low force approach stroke. Once the adjustable limit switch is initiated, the control system shifts into a hydraulic intensified boost/power stroke (which can range from 0 to 6.0"). Once the operator release one or both actuators, the cylinder rod/ram returns to home position. (Available Options: DR,TD, PSRO, 24VDC, PLC, SLC, SS1122, E-LPT, SIG)

Available Control Options

- DR = Distance Initiated w/Adjustable Timer Delay Ram Return
- TD = Pressure Initiated w/Adjustable Timer Delay Ram Return
- PSRO = Pressure Initiated Ram Return
- AS = Dual Regulated System (Air Savings)

EDP = Electric

(120V Control Power Needed)

DP-1-NP or EDP-1-NP Control Package:

Two-hand non-tie down jog control package. The operator initiates both actuators at the same time to advance the press stroke. If the operator releases one of both actuators during the downward stroke, the cylinder rod/ram stops its downward motion. The operator can either proceed with the downward cycle by re-initiating the actuators until press force or stroke distance is achieved, or manually retract the cylinder rod/ram to home position by pressing the manual retract button. Standard with PSRO option. (Available Options & Add-On Features: DR, TD, 24VDC, PLC, SLC, SS1122, E-LPT, SIG)

EDP-3 Control Package:

Muting/capture control package with adjustable (0 to 10 sec.) timer delay cylinder rod/ram return. The operator initiated both actuators at the same time to advance the press stroke. Once the cylinder rod/ram meets the work piece (closing the pinch point), an indicator turns on notifying the operator that they can remove their hands from the actuators. The cylinder rod/ram remains extended. The cylinder rod/ram automatically returns to home position once the timer is complete. Note: if the operator removes one or both hands from the actuator before the indicator turns on, the cylinder rod/ram returns to home position without starting the mute/capture sequence. Standard with TD option. (Available with DR, 24VDC, PLC, SLC, SS1122, E-LPT, SIG)

Add-On Features

- 24VDC = 24VDC Control Circuits
- PLC = Programmable Logic Controller
- SLC = Safety Light Curtain with Guarding
- SS1122 = Load Cell (Force) Monitoring
- E-LPT = Linear (Distance) Position Monitoring
- SIG = Both Force over Distance Monitoring (Signature)

Contact Us Today Phone: 1-800-837-4355 or Email: info@airhydraulics.com